

**LDM valves
with pneumatic actuators Flowserve (Foxboro)**



Kv coefficient calculation

Calculation itself is carried out with respect to conditions of regulating circuit and operating medium according to equations mentioned below. Control valve must be designed to be able to regulate maximal flow quantity at given operating conditions. At the same time it is necessary to check whether minimal flow quantity can be even regulated or not.

Condition is the following ratio $r > Kvs / K_{v_{min}}$

Because of eventual minus tolerance 10% of $K_{v_{100}}$ against Kvs and requirement for possible regulation within range of maximal flow (decrement and increase of flow), producer recommends to select Kvs value higher than maximal operating Kv value:

$$Kvs = 1.1 \div 1.3 K_v$$

It is necessary to take into account to which extent Q_{max} involve "precautionary additions" that could result in valve oversizing.

Relations of Kv calculation

		Pressure drop $p_2 > p_1/2$ $\Delta p < p_1/2$	Pressure drop $\Delta p \geq p_1/2$ $p_2 \leq p_1/2$
Kv =	Liquid	$\frac{Q}{100} \sqrt{\frac{\rho_1}{\Delta p}}$	$\frac{2 \cdot Q_n \cdot \sqrt{\rho_n \cdot T_1}}{5141 \cdot p_1}$
	Gas	$\frac{Q_n \cdot \sqrt{\rho_n \cdot T_1}}{5141 \cdot \Delta p \cdot p_2}$	$\frac{2 \cdot Q_n \cdot \sqrt{\rho_n \cdot T_1}}{5141 \cdot p_1}$
	Superh. steam	$\frac{Q_m}{100} \sqrt{\frac{v_2}{\Delta p}}$	$\frac{Q_m}{100} \sqrt{\frac{2v}{p_1}}$
	Sat. steam	$\frac{Q_m}{100} \sqrt{\frac{v_2 \cdot x}{\Delta p}}$	$\frac{Q_m}{100} \sqrt{\frac{2v \cdot x}{p_1}}$

Above critical flow of vapours and gases

When pressure ratio is above critical ($p_2 / p_1 < 0.54$), speed of flow reaches acoustic velocity at the narrowest section. This event can cause higher level of noisiness. Then it is convenient to use a throttling system ensuring low noisiness (multi-step pressure reduction, damping orifice plate at outlet).

Dimensions and units

Marking	Unit	Name of dimension
Kv	$m^3 \cdot h^{-1}$	Flow coefficient under condition of units of flow
$K_{v_{100}}$	$m^3 \cdot h^{-1}$	Flow coefficient at nominal stroke
$K_{v_{min}}$	$m^3 \cdot h^{-1}$	Flow coefficient at minimal flow rate
Kvs	$m^3 \cdot h^{-1}$	Valve nominal flow coefficient
Q	$m^3 \cdot h^{-1}$	Flow rate in operating conditions (T_1, p_1)
Q_n	$Nm^3 \cdot h^{-1}$	Flow rate in normal conditions ($0^\circ C, 0.101 Mpa$)
Q_m	$kg \cdot h^{-1}$	Flow rate in operating conditions (T_1, p_1)
p_1	MPa	Upstream absolute pressure
p_2	MPa	Downstream absolute pressure
p_s	MPa	Absolute pressure of saturated steam at given temperature (T_1)
Δp	MPa	Valve differential pressure ($\Delta p = p_1 - p_2$)
ρ_1	$kg \cdot m^{-3}$	Process medium density in operating conditions (T_1, p_1)
ρ_n	$kg \cdot Nm^{-3}$	Gas density in normal conditions ($0^\circ C, 0.101 Mpa$)
v_2	$m^3 \cdot kg^{-1}$	Specific volume of steam when temperature T_1 and pressure p_2
v	$m^3 \cdot kg^{-1}$	Specific volume of steam when temperature T_1 and pressure $p_1/2$
T_1	K	Absolute temperature at valve inlet ($T_1 = 273 + t_1$)
x	1	Proportionate weight volume of saturated steam in wet steam
r	1	Rangeability

Flow characteristic selection in regard of valve stroke

To make right selection of valve flow characteristic, it is suitable to carry out checking of what stroke values will be reached in different operation states. We recommend to carry out such checking at least for minimal, nominal and maximal flow rates. The principle for flow characteristic selection is to avoid, if possible, 5-10% of the beginning and end of the valve stroke range.

To calculate valve stroke at different operating conditions with different types of flow characteristics is possible with the advantage of using LDM's calculation programme VALVES. The programme serves for complete design of valve from Kv calculation to specification of a concrete valve with its actuator.

Valve flow characteristics

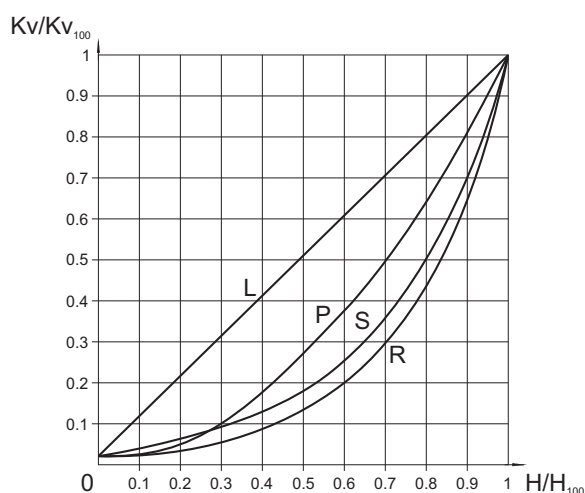

- L - linear characteristic
 $Kv/Kv_{100} = 0.0183 + 0.9817 \cdot (H/H_{100})$
- R - equal-percentage characteristic (4-percentage)
 $Kv/Kv_{100} = 0.0183 \cdot e^{(4 \cdot H/H_{100})}$
- P - parabolic characteristic
 $Kv/Kv_{100} = 0.0183 + 0.9817 \cdot (H/H_{100})^2$
- S - LDM spline[®] characteristic
 $Kv/Kv_{100} = 0.0183 + 0.269 \cdot (H/H_{100}) - 0.380 \cdot (H/H_{100})^2 + 1.096 \cdot (H/H_{100})^3 - 0.194 \cdot (H/H_{100})^4 - 0.265 \cdot (H/H_{100})^5 + 0.443 \cdot (H/H_{100})^6$

Principles for plug type selection

V-ported plugs should not be used in above - critical differential pressures with inlet pressure $p_1 \geq 0,4$ MPa and for regulation of saturated steam. In these cases we recommend to use a perforated plug. The perforated plug should be also used always when cavitation may occur due to a high differential pressure value or valve ports erosion caused by high speed of process medium flow. If the parabolic plug is used (because of small Kvs) for pressures $p_1 \geq 1,6$ MPa and above - critical differential pressures, it is necessary to close both plug and seat with a hard metal overlay, i.e. stellite trim.

Packing - O -ring EPDM

Packing is designed for non-aggressive media with temperature from 0°C to 140°C. Packing excels with its reliability and long time tightness. It has ability of sealing even if the valve stem is a bit damaged. Low frictional forces enables valve to be actuated with a low-linear-force actuator. Service life of sealing rings depends on operating conditions and it is more than 400 000 cycles on average.

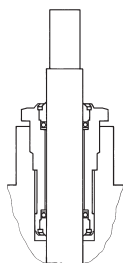

Applied to RV 2xx

Packing - DRSpack® (PTFE)

DRSpack® (Direct Radial Sealing Pack) is a packing with high tightness at both low and high operating pressure values. It is the most used type of packing suitable for temperatures ranging from 0°C to 260°C. The pH range is from 0 to 14. The packing enables using of actuators with low linear force. The design enables an easy change of the whole packing. The average service life of DRSpack® is more than 500 000 cycles.

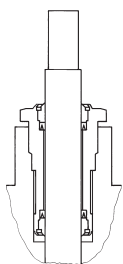

Service life of bellows packing

Bellows material	Temperature				
	200°C	300°C	400°C	500°C	550°C
1.4541	100 000	40 000	28 000	7 000	not applicable
1.4571	90 000	34 000	22 000	13 000	8 000

Values specified in the table above show minimal guaranteed number of cycles with the valve full stroke when the bellows is fully lengthened and pressed. In regulation, when the valve

Packing - Graphite

This type of packing can be used for media with temperature up to 550°C and pH range: 0 to 14. Packing can be "sealed up" either by screwing the packing screw in or adding another sealing ring. In regard of intensive frictional forces, graphite packing is suitable for actuators with a sufficient linear force.

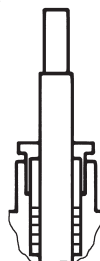

Packing - Bellows

Bellows packing is suitable for low and high temperatures ranging from -50°C to 550°C. Bellows ensures absolute tightness to environment. Packing is equipped with safety PTFE packing as standard to prevent medium from leaking in case of damage to bellows. Intensive linear forces are not required.

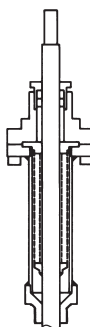

Application of bellows packing

Bellows packing is suitable for applications with very aggressive, toxic or other dangerous media that require absolute tightness to environment. In such case, it is necessary to check compatibility of used body material as well as the valve inner parts material with process medium. It is recommended to use bellows with safety packing preventing medium from leaking in case of damage to bellows when there is an extremely dangerous process medium used.

Bellows is also a great solution to use of process medium either with temperature below zero when ice accretions cause premature damage to packing or with high temperatures when bellows ensures medium cooling.

moves only in a portion of the stroke range at the inner centre of the valve, the service life of the bellows is many times longer then depending on concrete operating conditions.

Procedure for designing of two-way valve

Given: medium water, 155°C, static pressure at piping spot 1000 kPa (10 bar), $\Delta p_{DISP} = 80$ kPa (0,8 bar), $\Delta p_{PIPELINE} = 15$ kPa (0,15 bar), $\Delta p_{APPLIANCE} = 25$ kPa (0,25 bar), nominal flow rate $Q_{NOM} = 8$ m³·h⁻¹, minimal flow rate $Q_{MIN} = 1,3$ m³·h⁻¹.

$$\Delta p_{DISP} = \Delta p_{VALVE} + \Delta p_{APPLIANCE} + \Delta p_{PIPELINE}$$

$$\Delta p_{VALVE} = \Delta p_{DISP} - \Delta p_{APPLIANCE} - \Delta p_{PIPELINE} = 80 - 25 - 15 = 40 \text{ kPa (0,4 bar)}$$

$$Kv = \frac{Q_{NOM}}{\sqrt{\Delta p_{VALVE}}} = \frac{8}{\sqrt{0,4}} = 12,7 \text{ m}^3 \cdot \text{h}^{-1}$$

Precautionary additions for process tolerances (provided that flow rate Q was not oversized):

$$Kvs = (1,1 \text{ to } 1,3) \cdot Kv = (1,1 \text{ to } 1,3) \cdot 12,7 = 14 \text{ to } 16,5 \text{ m}^3 \cdot \text{h}^{-1}$$

Now we choose the nearest Kvs value from those available in our catalogue, i.e. $Kvs = 16$ m³·h⁻¹. This value corresponds to nominal size of DN 32. Then if we choose flanged execution PN 16, body made of spheroidal cast iron, with metal - PTFE seat sealing, packing PTFE and equal-percentage flow characteristic, we will get the following specification No.:

RV 21x XXX 1423 R1 16/220-32

x in the valve code above (21x) stands for valve execution (direct or reverse) and depends on type of used actuator which should be chosen in respect to demands of regulating system (type, producer, voltage, type of control, necessary torque or linear force, etc.).

Determination of real pressure drop value of a chosen valve at fully open

$$\Delta p_{VALVE H100} = \left(\frac{Q_{NOM}}{Kvs} \right)^2 = \left(\frac{8}{16} \right)^2 = 0,25 \text{ bar (25 kPa)}$$

The control valve's real pressure drop calculated this way shall be taken into account in a hydraulic calculation of regulating circuit.

Determination of valve's real authority

$$a = \frac{\Delta p_{VALVE H100}}{\Delta p_{VALVE H0}} = \frac{25}{80} = 0,31$$

Value a should be at least equal to 0,3. A chosen valve checking is then satisfactory.

Caution: the valve's authority calculation should be related to a valve pressure difference in its closed position i.e. disposition pressure value in a branch Δp_{AVAIL} when flow rate is zero, not to a pressure value of a pump Δp_{PUMP} , because, due to pipeline circuit pressure drops up to the spot where the regulating branch is connected, the following equation applies: $\Delta p_{AVAIL} < \Delta p_{PUMP}$. In such cases we consider for simplicity the following: $\Delta p_{AVAIL H100} = \Delta p_{AVAIL H0} = \Delta p_{DISP}$.

Checking of rangeability

We carry out the same checking for minimal flow rate $Q_{MIN} = 1,3$ m³·h⁻¹. The following differential pressure values correspond to the min. flow rate: $\Delta p_{APPLIANCE QMIN} = 0,40$ kPa, $\Delta p_{PIPELINE QMIN} = 0,66$ kPa. $\Delta p_{VALVE QMIN} = 80 - 0,4 - 0,66 = 78,94 = 79$ kPa.

$$Kv_{MIN} = \frac{Q_{MIN}}{\sqrt{\Delta p_{VALVE QMIN}}} = \frac{1,3}{\sqrt{0,79}} = 1,46 \text{ m}^3 \cdot \text{h}^{-1}$$

Necessary rangeability value

$$r = \frac{Kvs}{Kv_{MIN}} = \frac{16}{1,46} = 11$$

shall be lower than mentioned rangeability value of $r = 50$. Checking is then satisfactory.

Selection of suitable flow characteristic

On the basis of calculated values Kv_{NOM} and Kv_{MIN} , it is possible to read the appropriate stroke values from the graph for individual types of flow characteristics of the valve and choose the most suitable one accordingly. Here we have $h_{NOM} = 96\%$, $h_{MIN} = 41\%$ for equal-percentage characteristic. In that case, LDMspline® flow characteristic is more suitable (93% and 30% of the stroke). It corresponds to the following specification code :

RV 21x XXX 1423 S1 16/220-32

Scheme of typical regulation loop with the application of two-way control valve

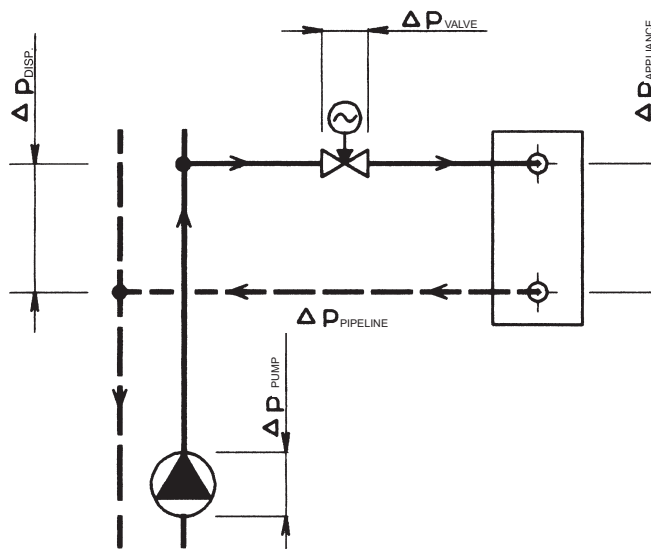

Remark: More detailed information on calculation and design of LDM control valves is mentioned in calculation instructions No. 01-12.0. Equations mentioned above apply in a simplified way to water. To reach optimum results, we recommend to use original calculation programme VALVES which is available on request free of charge.

Procedure for designing of three-way valve

Given: medium water, 90°C, static pressure at piping spot 1000 kPa (10 bar), $\Delta p_{\text{PUMP2}} = 40 \text{ kPa}$ (0,4 bar), $\Delta p_{\text{PIPELINE}} = 10 \text{ kPa}$ (0,1bar), $\Delta p_{\text{APPLIANCE}} = 20 \text{ kPa}$ (0,2 bar), flow rate $Q_{\text{NOM}} = 7 \text{ m}^3 \cdot \text{h}^{-1}$

$$\Delta p_{\text{PUMP2}} = \Delta p_{\text{VALVE}} + \Delta p_{\text{APPLIANCE}} + \Delta p_{\text{PIPELINE}}$$

$$\Delta p_{\text{VALVE}} = \Delta p_{\text{PUMP2}} - \Delta p_{\text{APPLIANCE}} - \Delta p_{\text{PIPELINE}} = 40 - 20 - 10 = 10 \text{ kPa} (0,1\text{bar})$$

$$Kv = \frac{Q_{\text{NOM}}}{\sqrt{\Delta p_{\text{VALVE}}}} = \frac{7}{\sqrt{0,1}} = 22,1 \text{ m}^3 \cdot \text{h}^{-1}$$

Precautionary additions for process tolerances (provided that flow rate Q was not oversized):

$$Kvs = (1,1 \text{ to } 1,3) \cdot Kv = (1,1 \text{ to } 1,3) \cdot 22,1 = 24,3 \text{ to } 28,7 \text{ m}^3 \cdot \text{h}^{-1}$$

Now we choose the nearest Kvs value from those available in our catalogue, i.e. $Kvs = 25 \text{ m}^3 \cdot \text{h}^{-1}$. This value corresponds to nominal size of DN 40. Then if we choose flanged execution PN 16, body made of spheroidal cast iron, with metal - PTFE seat sealing, packing PTFE and equal-percentage flow characteristic, we will get the following specification No.:

RV 21x XXX 1413 L1 16/140-40

x in the valve code above (21x) stands for valve execution (direct or reverse) and depends on type of used actuator which should be chosen in respect to demands of regulating system (type, producer, voltage, type of control, necessary torque or linear force, etc.)

Determination of real pressure drop value of a chosen valve at fully open

$$\Delta p_{\text{VALVE H100}} = \left(\frac{Q_{\text{NOM}}}{Kvs} \right)^2 = \left(\frac{7}{25} \right)^2 = 0,08 \text{ bar} (8 \text{ kPa})$$

The control valve's real pressure drop calculated this way shall be taken into account in a hydraulic calculation of regulating circuit.

Caution: To ensure reliable function of three-way valves, the most important condition is to keep minimum available pressure difference between A and B ports. Three-way valves are capable to manage even high pressure difference between A and B ports but valve's flow characteristic deformats then and so regulation properties deteriorate. So if in doubt about pressure difference value between those two ports (e.g. when three-way valve is piped directly into primary side without pressure separation), we recommend to use a two-way valve in combination with a primary-secondary side short cut to ensure a reliable regulation. The authority of A-AB way of three-way valve is, providing a constant flow rate in appliance circuit, the following:

$$a = \frac{\Delta p_{\text{VALVE H100}}}{\Delta p_{\text{VALVE H0}}} = \frac{8}{8} = 1 ,$$

which means that the behaviour of flow in A-AB way corresponds to ideal flow curve of the valve. In that case there are Kvs values in both ports the same with linear characteristic i.e. the total flow is nearly constant.

A combination of equal-percentage characteristic in A port and linear characteristic in B port shall be selected in those cases when loading of A port with differential pressure against B port cannot be avoided or when the primary side parametres are too high.

Scheme of a typical regulation loop with the application of a three-way mixing control valve

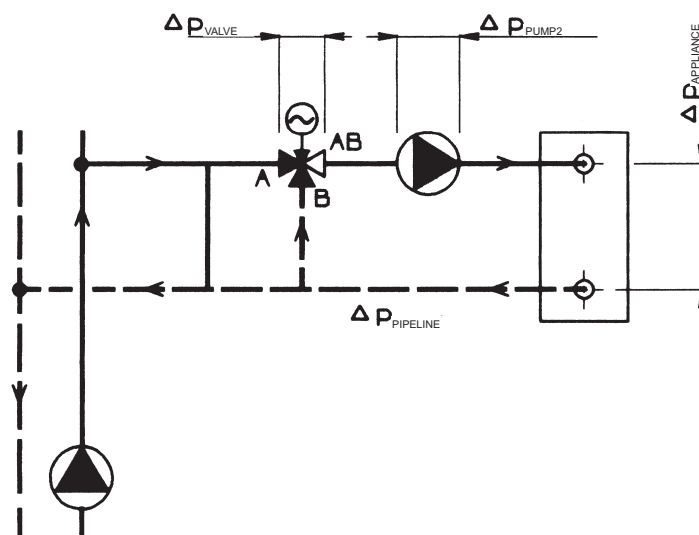

Remark: More detailed information on calculation and design of LDM control valves is mentioned in calculation instructions No. 01-12.0. Equations mentioned above apply in a simplified way to water. To reach optimum results, we recommend to use original calculation programme VALVES which is available on request free of charge.

RV / UV 2x0 P (Ex)

Control and Shut-off valves DN 15 - 400, PN 16, 25 and 40 with pneumatic actuators



Description

Control valves RV / UV 210 (Ex), RV / UV 220 (Ex) and RV / UV 230 [further only RV / UV 2x0 (Ex)] are single-seated valves designed for regulation and shut-off of process medium flow. In regard of used actuators, the valves are suitable for regulation at low and medium high differential pressures. Flow characteristics, Kvs values and leakage rates correspond to international standards.

Valves RV / UV 2x0 (Ex) are especially designed for pneumatic actuators of Flowserve.

Application

The valves series RV / UV 2x0 are designed for applications in heating, ventilation, power generation and chemical processing industries. The valves RV / UV 2x0 Ex meet the requirements II 1/2G IIB acc. to ČSN-EN 13 463-1 (9/2002) and ČSN EN 1127-1 (9/1998), and in connection with suitable actuators, they are also designed for applications in gas and chemical industries. Valve body can be optionally made of spheroidal cast iron, cast steel and stainless steel.

The materials selected correspond to recommendations stipulated by ČSN-EN 1503-1 (1/2002) (steels) and ČSN-EN 1503-3 (1/2002) (cast). The maximal permissible operating pressures in behaviour with types of material and temperature are specified in the table on page 28 of this catalogue.

Process media

Valves series RV (UV) 2x0 are designed for regulation (RV 2x0) and shut-off (UV 2x0) of flow and pressure of liquids, gases and vapours without abrasive particles e.g. water, steam, air and other media compatible with material of the valve inner parts. The valves series RV / UV 2x0 Ex are designed also for control and shut-off of the flow and pressure of technical and fuel gases and inflammable liquids. The usage of the valve made of spheroidal cast iron (RV 210) for steam is limited by the following parameters. The steam must be superheated (its dryness at valve outlet $x_1 \geq 0,98$) and inlet pressure $p_1 \leq 0,4$ MPa when differential pressure is of above-critical value, and $p_1 \leq 1,6$ MPa when differential pressure is of under-critical value. In case these two conditions are not kept, it is necessary to use the valve made of cast steel (RV 220). To ensure a reliable regulation, the producer recommends to pipe a strainer in front of the valve into pipeline or ensure in any other way that process medium does not contain abrasive particles or impurities.

Installation

The valve is to be piped the way so that the direction of medium flow will coincide with the arrows on the body.

The valve can be installed in any position except position when the actuator is under the valve body. When medium temperature exceeds 150°C, it is necessary to protect the actuator against glowing heat from the pipeline e.g. by the means of proper insulating of the pipeline and valve or by tilting the valve away from the heat radiation.

Technical data

Series	RV / UV 210 (Ex)	RV / UV 220 (Ex)	RV / UV 230 (Ex)
Type of valve	Two-way, single-seated, control (shut-off) valve		
Nominal size range	DN 15 to 400		
Nominal pressure	DN 15 to 150: PN 16, 40 DN 200 to 400: PN 16	PN 16, 25, 40	
Body material	Spheroidal cast iron EN-JS 1025 (EN-GJS-400-10-LT)	Cast steel 1.0619 (GP240GH) 1.7357 (G17CrMo5-5)	Stainless steel 1.4581 (GX5CrNiMoNb19-11-2)
Seat material: DN 15 - 50	1.4028 / 17 023.6	1.4028 / 17 023.6	1.4571 / 17 348.4
DIN W.Nr./ČSN DN 80 - 400	1.4027 / 42 2906.5	1.4027 / 42 2906.5	1.4581 / 42 2941.4
Plug material : DN 15 - 65	1.4021 / 17 027.6	1.4021 / 17 027.6	1.4571 / 17 348.4
DIN W.Nr./ČSN DN 80 - 150	1.4027 / 42 2906.5	1.4027 / 42 2906.5	1.4581 / 42 2941.4
DN 200 - 400	1.4021 / 17 022.6	1.4021 / 17 022.6	1.4581 / 42 2941.4
Operating temperature range	-20 to 300°C	-20 to 500°C	-20 to 400°C
Face to face dimensions	Section 1 acc. ČSN-EN 558-1 (3/1997)		
Connection flanges	Dle ČSN-EN 1092-1 (4/2002)		
Flange faces	Type B1 (raised-faced) acc. to ČSN-EN 1092-2 (1/1999)	Type B1 (raised-faced) or Type F (female) or type D (groove) according to ČSN-EN 1092-1 (2/2003)	
Type of plug	V-ported, contoured, perforated		
Flow characteristic	Linear, equal-percentage, LDMspline®, parabolic, on - off		
Kvs value	0.01 až 1600 m ³ /hod		
Leakage rate	Class III. acc. to ČSN-EN 1349 (5/2001) (<0.1% Kvs) for c. valves with metal-metal seat sealing Class IV. acc. to ČSN-EN 1349 (5/2001) (<0.01% Kvs) for c. valves with metal-PTFE seat sealing Class IV. acc. to ČSN-EN 1349 (5/2001) (<0.01% Kvs) for shut-off valves		
Leakage rate for Ex version	Leakage rate 6 acc. to ČSN 13 3060 - section 2		
Rangeability r	50 : 1		
Packing	O - ring EPDM $t_{max}=140^{\circ}C$, DRSpack® (PTFE) $t_{max}=260^{\circ}C$, Exp. graphite, bellows $t_{max}=500^{\circ}C$		

Kvs values and differential pressures Δp_{\max} Pa for valves D to

- -ported plugs, contoured plugs flow direction elow plug

Δp_{\max} value is the valve max. differential pressure when open-close function is always guaranteed. In regard of service life of seat and plug, it is recommended so that permanent

differential pressure would not exceed 1.6 MPa. Otherwise it is suitable to use perforated plug or sealing surfaces of seat and plug with a hard metal overlay.

For further information on actuating, see actuators' catalogue sheets		Pneumatic actuators		PA 127		PA 252		PB 502														
		Specification No. of actuator	BADxAA	BFYxZA	BADxAA	BVCxZA	BADxAB	BVCxZB														
		Actuator function		direct	indirect	direct	indirect	direct	indirect													
		Spring range [bar]		0,2 - 1,0	2,0 - 4,8	0,2 - 1,0	1,5 - 2,7	0,2 - 1,0	1,5 - 2,7													
		Spring setting [bar]		0,2 - 0,84	2,56 - 4,8	0,2 - 0,84	1,75 - 2,7	0,2 - 0,7	1,95 - 2,7													
		Feeding pressure [bar]		6,0	5,0	3,0	2,9	3,0	2,9													
		Marking in valve specification No.		PFF		PFA		PFB														
		Linear force		6,2 kN	3,2 kN	4,9 kN	4,35 kN	10,5 kN	9,75 kN													
		Kvs [m ³ /h]		Δp_{\max}	Δp_{\max}	Δp_{\max}	Δp_{\max}	Δp_{\max}	Δp_{\max}													
DN	H	1	2	3	4	5	6	7	8	9	met PTFE	met PTFE	met PTFE	met PTFE	met PTFE	met PTFE						
15	16	---	2.5 ¹⁾	1.6 ¹⁾	1.0 ¹⁾	0.6 ¹⁾	0.4 ¹⁾	0.25 ¹⁾	0.16 ³⁾	0.1 ³⁾	4.00	---	4.00	---	4.00	---	4.00	---	---	---		
15		4.0 ¹⁾	---	---	---	---	---	---	---	---	4.00	---	4.00	---	4.00	---	4.00	---	---	---		
20		---	---	2.5 ¹⁾	1.6 ¹⁾	1.0 ¹⁾	0.6 ¹⁾	---	---	---	---	4.00	---	4.00	---	4.00	---	4.00	---	---	---	
20		---	4.0 ¹⁾	---	---	---	---	---	---	---	---	4.00	---	4.00	---	4.00	---	4.00	---	---	---	
20		6.3 ¹⁾	---	---	---	---	---	---	---	---	---	4.00	---	4.00	---	4.00	---	4.00	---	---	---	
25		---	---	---	2.5 ¹⁾	1.6 ¹⁾	---	---	---	---	---	4.00	---	4.00	---	4.00	---	4.00	---	---	---	
25		10.0	6.3 ²⁾	4.0 ²⁾	---	---	---	---	---	---	---	4.00	4.00	4.00	4.00	4.00	4.00	4.00	4.00	---	---	
32		---	---	---	4.0 ¹⁾	---	---	---	---	---	---	4.00	---	4.00	---	4.00	---	4.00	---	---	---	
32		16.0	10.0	6.3 ²⁾	---	---	---	---	---	---	---	4.00	4.00	2.61	2.92	4.00	4.00	3.88	4.00	---	---	
40		25.0	16.0	10.0	---	---	---	---	---	---	---	3.75	4.00	1.62	1.87	2.83	3.08	2.44	2.69	---	---	
50	25	40.0	25.0	16.0	---	---	---	---	---	---	---	---	---	---	---	---	---	---	4.00	4.00	3.71	3.91
65		63.0	40.0	25.0	---	---	---	---	---	---	---	---	---	---	---	---	---	---	---	2.43	2.58	2.23

For further information on actuating, see actuators' catalogue sheets		Pneumatic actuators		PB 502		PB 700													
		Specification No. of actuator	BADxAB	BVCxZB	BADxAB	BVCxZB													
		Actuator function		direct	indirect	direct	indirect												
		Spring range [bar]		0,2 - 1,0	1,5 - 2,7	0,2 - 1,0	1,5 - 2,7												
		Spring setting [bar]		0,2 - 1,0	1,5 - 2,7	0,2 - 1,0	1,5 - 2,7												
		Feeding pressure [bar]		3,0	2,9	3,2	2,9												
		Marking in valve specification No.		PFB		PFC													
		Linear force		9,0 kN	7,5 kN	14 kN	10,5 kN												
		Kvs [m ³ /h]		Δp_{\max}	Δp_{\max}	Δp_{\max}	Δp_{\max}												
DN	H	1	2	3	4	5	6	7	8	9	met PTFE	met PTFE	met PTFE	met PTFE					
80	40	100.0	63.0	40.0	---	---	---	---	---	---	1.28	1.40	1.01	1.13	2.18	2.30	1.55	1.67	
100		160.0	100.0	63.0	---	---	---	---	---	---	---	0.80	0.91	0.63	0.73	1.39	1.49	0.98	1.08
125		250.0	160.0	100.0	---	---	---	---	---	---	---	0.50	0.59	0.39	0.47	0.88	0.96	0.61	0.70
150		360.0	250.0	160.0	---	---	---	---	---	---	---	0.34	0.41	0.26	0.33	0.60	0.68	0.42	0.49

1) parabolic plug
 2) V-ported plug with linear characteristic, parabolic plug with equal-percentage, LDMspline® and parabolic characteristic
 3) valve with micro-throttling trim. Execution with Kvs 0.01 to 0.063 m³/hour is possible after agreement with the produce.
 Equal-percentage, LDMspline® and parabolic characteristic available on condition: Kvs value ≥ 1.0
 Max. differential pressure Δp for valves PN 16 must be 1.6 MPa.
 metal - version with metal - metal seat sealing
 PTFE - version with metal - PTFE seat sealing (is not applicable to contoured plugs)

Max. differential pressures specified in table apply to PTFE and O-ring packing. Δp_{\max} for bellows must be consulted with the producer. It applies to graphite packing as well especially when required Δp value is close to max. values specified in table.

Δp_{\max} values are set for the most unfavourable pressure ratios on the valve PN 40, but in concrete cases the real Δp_{\max} value can be higher than values specified in the table above.

Kvs values and differential pressures Δp_{max} [MPa] for valves DN 15 to 150 with Flowserve actuators - perforated plugs (low direction above plug)

Δp_{max} value is the valve max. differential pressure when open-close function is always guaranteed.

For further information on actuating, see actuators' catalogue sheets		Pneumatic actuators						PA 252				PB 502			
		Specification No. of actuator						BVCxAA		BVCxZA		BVCxAB		BVCxZB	
		Actuator function						direct		indirect		direct		indirect	
		Spring range [bar]						1,5 - 2,7		1,5 - 2,7		1,5 - 2,7		1,5 - 2,7	
		Spring setting [bar]						1,5 - 2,46		1,75 - 2,7		1,5 - 2,25		1,95 - 2,7	
		Feeding pressure [bar]						4,0		4,5		3,8		4,7	
		Marking in valve specification No.						PFA				PFB			
		Linear force						3,7 kN		4,35 kN		7,5 kN		9,75 kN	
		Kvs [m ³ /h]						packing		packing		packing		packing	
DN	H	1	2	3	4	5	6	graphit	PTFE	graphit	PTFE	graphit	PTFE	graphit	PTFE
25	16	---	6.3	4	2.5	1.6	---	0.55	1.33	0.79	1.56	---	---	---	---
32		---	10	6.3	4.0	2.5	1.6	0.33	0.80	0.48	0.95	---	---	---	---
40		---	16	10	6.3	4.0	2.5	0.21	0.52	0.31	0.61	---	---	---	---
50	25	---	25	16	10	6.3	4.0	---	---	---	---	0.45	0.63	0.64	0.82
65		---	40	25	16	10	6.3	---	---	---	---	0.28	0.39	0.39	0.50

For further information on actuating, see actuators' catalogue sheets		Pneumatic actuators						PB 502				PB 700			
		Specification No. of actuator						BVCxAB		BVCxZB		BADxAB		BVCxZB	
		Actuator function						direct		indirect		direct		indirect	
		Spring range [bar]						1,5 - 2,7		1,5 - 2,7		1,5 - 2,7		1,5 - 2,7	
		Spring setting [bar]						1,5 - 2,7		1,5 - 2,7		1,5 - 2,7		1,5 - 2,7	
		Feeding pressure [bar]						4,2		4,2		4,2		4,2	
		Marking in valve specification No.						PFB				PFC			
		Linear force						7,5 kN		7,5 kN		10,5 kN		10,5 kN	
		Kvs [m ³ /h]						packing		packing		packing		packing	
DN	H	1	2	3	4	5	6	graphit	PTFE	graphit	PTFE	graphit	PTFE	graphit	PTFE
80	40	---	63	40	25	16	10	0.18	0.27	0.18	0.27	0.28	0.37	0.28	0.37
100		---	100	63	40	25	16	0.11	0.17	0.11	0.17	0.18	0.24	0.18	0.24
125		---	160	100	63	40	25	0.07	0.11	0.07	0.11	0.12	0.16	0.12	0.16
150		---	250	160	100	63	40	0.05	0.08	0.05	0.08	0.08	0.11	0.08	0.11

Perforated plugs is possible to delivery with following limitations:

- Kvs values 2.5 and 1.6 m³/hod with linear characteristic only
- is possible to delivery perforated plug with linear or parabolic characteristic with Kvs value according to the column No.2

Max. differential pressure Δp for valves PN 16 must be 1,6 MPa.

Max. differential pressures specified in table apply to **PTFE and graphite packing**. Δp_{max} for bellows must be consulted with the producer.

Max. differential pressures are valid for metal-metal seat sealing and for hard metal overlay on sealing surfaces.

Kvs values and differential pressures Δp_{max} Pa for valves D to - -ported plugs flow direction elow plug

Δp_{max} value is the valve max. differential pressure when open-close function is always guaranteed. In regard of service life of seat and plug, it is recommended so that permanent

differential pressure would not exceed 1.6 MPa. Otherwise it is suitable to use perforated plug or sealing surfaces of seat and plug with a hard metal overlay.

For further information on actuating, see actuators' catalogue sheets			Pneumatic actuators		PO 1502								
			Specification No. of actuator		BGFxAD	BVCxZD	BGFxAD	BFSxZD	BGFxAD	BAJxZD			
			Actuator function		direct	indirect	direct	indirect	direct	indirect			
			Spring range [bar]		0,4 - 2,0	1,5 - 2,7	0,4 - 2,0	2,0 - 3,5	0,4 - 2,0	2,6 - 4,2			
			Spring setting [bar]		0,4 - 2,0	1,5 - 2,7	0,4 - 2,0	2,0 - 3,5	0,4 - 2,0	2,6 - 4,2			
			Feeding pressure [bar]		3,5	3,1	4,0	3,9	4,6	4,6			
			Marking in valve specification No.		PFD								
			Linear force		22,5 kN	22,5 kN	30 kN	30 kN	38 kN	38 kN			
			Kvs [m ³ /h]		packing	packing	packing	packing	packing	packing			
DN	Ds	H	1	2	3	4	5	graphitPTFE	graphitPTFE	graphitPTFE	graphitPTFE	graphitPTFE	graphitPTFE
200	100	80	---	---	250	160	100	2.01 2.35	2.01 2.35	2.90 3.24	2.90 3.24	3.85 4.00	3.85 4.00
	150		---	400	---	---	---	0.88 1.03	0.88 1.03	1.28 1.43	1.28 1.43	1.71 1.86	1.71 1.86
	200		570	---	---	---	---	0.48 0.57	0.48 0.57	0.71 0.80	0.71 0.80	0.96 1.04	0.96 1.04
250	150	80	---	---	400	250	160	0.82 0.99	0.82 0.99	1.22 1.40	1.22 1.40	1.66 1.83	1.66 1.83
	200		---	630	---	---	---	0.45 0.55	0.45 0.55	0.68 0.78	0.68 0.78	0.92 1.02	0.92 1.02
	230		800	---	---	---	---	0.33 0.41	0.33 0.41	0.51 0.58	0.51 0.58	0.69 0.77	0.69 0.77
300	200	80	---	---	630	400	250	0.45 0.55	0.45 0.55	0.68 0.78	0.68 0.78	0.92 1.02	0.92 1.02
	230		---	800	---	---	---	0.33 0.41	0.33 0.41	0.51 0.58	0.51 0.58	0.69 0.77	0.69 0.77
	250		1000	---	---	---	---	0.28 0.34	0.28 0.34	0.43 0.49	0.43 0.49	0.58 0.65	0.58 0.65

For further information on actuating, see actuators' catalogue sheets			Pneumatic actuators		PO 1502				---		
			Specification No. of actuator		BDYxAE	BFYxZE	BDYxAE				
			Actuator function		direct	indirect	direct	indirect			
			Spring range [bar]		1,0 - 2,4	2,0 - 4,8	1,0 - 2,4				
			Spring setting [bar]		1,0 - 2,4	2,0 - 4,8	1,0 - 2,4				
			Feeding pressure [bar]		4,5	5,0	5,0				
			Marking in valve specification No.		PFD						
			Linear force		30 kN	30 kN	38 kN				
			Kvs [m ³ /h]		packing	packing	packing	packing			
DN	Ds	H	1	2	3	4	5	graphitPTFE	graphitPTFE	graphitPTFE	graphitPTFE
400	100	100	---	---	630	400	250	0.68 0.78	0.68 0.78	0.92 1.02	---
	250		---	1000	---	---	---	0.43 0.49	0.43 0.49	0.58 0.65	---
	330		1600	---	---	---	---	0.24 0.27	0.24 0.27	0.33 0.36	---

Max. differential pressures are valid for metal-metal seat sealing and for hard metal overlay on sealing surfaces.

Max. differential pressure Δp for valves PN 16 (PN 25) must be 1,6 MPa (2,5 MPa).

Valves RV 2x0 DN 200 to 400 with perforated plugs and pneumatic actuators is not possible to delivery.

Dimensions and weights of valves made of spheroidal cast iron RV / UV 210 (Ex), DN 15 to 150

DN	PN 16					PN 40					PN 16, PN 40												
	D ₁	D ₂	D ₃	d	n	D ₁	D ₂	D ₃	d	n	D	f	D ₄	D ₅	L	V ₁	V ₂	[#] V ₂	V ₃	[#] V ₃	a	m	[#] m _v
	mm	mm	mm	mm		mm	mm	mm	mm		mm	mm	mm	mm	mm	mm	mm	mm	mm	mm	mm	kg	kg
15	95	65	46	14	4	95	65	46	14	4	15	2	65	M10x1	130	51	90	257	220	387	14	4.5	3.5
20	105	75	56			105	75	56			20				150	54	90	257	220	387	16	5.5	3.5
25	115	85	65			115	85	65			25				160	58	100	267	230	397	16	6.5	3.5
32	140	100	76			140	100	76			32				180	70	100	267	230	397	18	8	3.5
40	150	110	84	19	8	150	110	84	19	8	40	3	65	M16x1,5	200	75	100	267	230	397	19	9	3.5
50	165	125	99			165	125	99			50				230	85	132	339	262	469	19	14	4
65	185	145	118			185	145	118			65				290	93	132	339	262	469	19	18	4
80	200	160	132			200	160	132			80				310	105	164	482	294	612	19	26	4.5
100	220	180	156	23	8	235	190	156	23	8	100			350	118	164	482	294	612	19	38	4.5	
125	250	210	184			270	220	184			125			400	135	183	501	313	631	23.5	58	5	
150	285	240	211			300	250	211			150			480	150	200	518	330	648	26	78	5	

Dimensions and weights of valves made of cast steel and stainless steel for the type RV / UV 220 (Ex), RV / UV 230 (Ex) DN 15 to 150

DN	PN 16					PN 40					PN 16, PN 40												
	D ₁	D ₂	D ₃	d	n	D ₁	D ₂	D ₃	d	n	D	f	D ₄	D ₅	L	V ₁	V ₂	[#] V ₂	V ₃	[#] V ₃	a	m	[#] m _v
	mm	mm	mm	mm		mm	mm	mm	mm		mm	mm	mm	mm	mm	mm	mm	mm	mm	mm	mm	kg	kg
15	95	65	45	14	4	95	65	45	14	4	15	2	65	M10x1	130	51	90	257	220	387	16	5.5	3.5
20	105	75	58			105	75	58			20				150	54	90	257	220	387	18	6.5	3.5
25	115	85	68			115	85	68			25				160	58	100	267	230	397	18	8	3.5
32	140	100	78			140	100	78			32				180	70	100	267	230	397	18	9.5	3.5
40	150	110	88	18	8	150	110	88	18	8	40	2	65	M16x1,5	200	75	100	267	230	397	18	11	3.5
50	165	125	102			165	125	102			50				230	85	132	339	262	469	20	21	4
65	185	145	122			185	145	122			65				290	93	132	339	262	469	22	27	4
80	200	160	138			200	160	138			80				310	105	164	482	294	612	24	40	4.5
100	220	180	158	22	8	235	190	162	22	8	100			350	118	164	482	294	612	24	49	4.5	
125	250	210	188			270	220	188			125			400	135	183	501	313	631	26	82	5	
150	285	240	212			300	250	218			150			480	150	200	518	330	648	28	100	5	

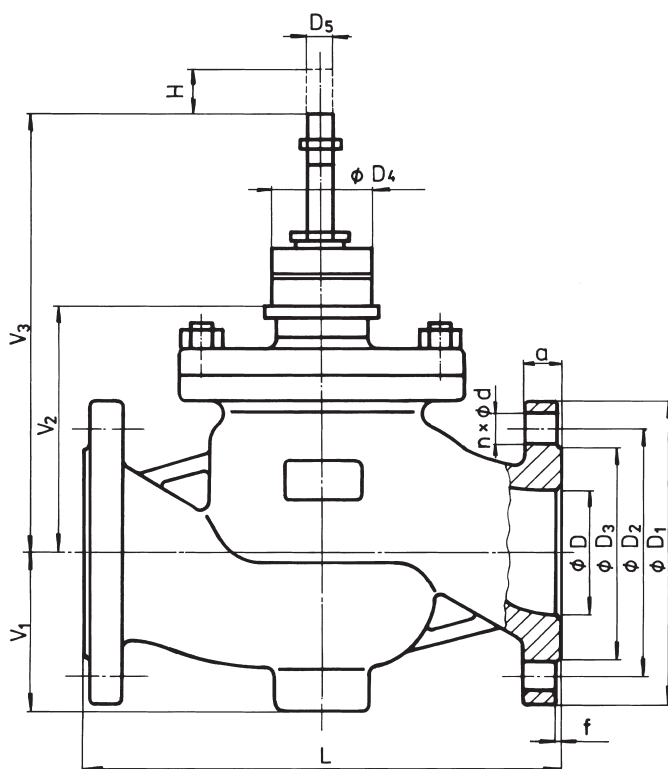

- ¹⁾ - with regard of the standard previously in force, there is an option to have the number of connection bolts as stipulated in ČSN-EN 1092- - for valve with bellows packing
 m_v - weight to be added to weight of valve if equipped with bellows packing

Dimensions and weights of valves made of spheroidal cast iron RV / UV 210 (Ex), DN 200 to 400

DN	PN 16																	
	D ₁	D ₂	D ₃	d	n	a	D	D ₅	M	L	V ₁	V ₂	V ₃	V ₄	f	H	m	
	mm	mm	mm	mm		mm	mm	mm	mm	mm	mm	mm	mm	mm	mm	mm	mm	kg
200	340	295	266	23	12	20	200	M20x1.5	150	600	203	262	422	160	3	80	141	
250	405	355	319	22		250	730			253	346	506	3		259			
300	460	410	370	24.5		300	850			296	395	555	4		364			
400	580	525	480	28	400	1100	382			512	672	4	100		747			

Dimensions and weights of valves made of cast steel and stainless steel for the type RV / UV 2x0 (Ex), DN 200 to 400

DN	PN 16						PN 25						PN 40					
	D ₁	D ₂	D ₃	d	n	a	D ₁	D ₂	D ₃	d	n	a	D ₁	D ₂	D ₃	d	n	a
	mm	mm	mm	mm		mm	mm	mm	mm	mm		mm	mm	mm	mm	mm		mm
200	340	295	268	22	12	24	360	310	278	26	12	30	375	320	285	30	12	34
250	405	355	320	26		26	425	370	335	30		32	450	385	345	33		38
300	460	410	378	28		485	430	395	36	16	34	515	450	410	33	42		
400	580	525	490	30	16	32	620	550	505		36	40	660	585	535	39	16	50

DN	PN 16, 25, 40										
	D	D ₅	M	L	V ₁	V ₂	V ₃	V ₄	f	H	m
	mm	mm	mm	mm	mm	mm	mm	mm	mm	mm	kg
200	200	M20x1.5	150	600	203	262	422	160	2	80	220
250	250			730	253	346	506				390
300	300			850	296	395	555				570
400	400			1100	382	512	672			100	1170

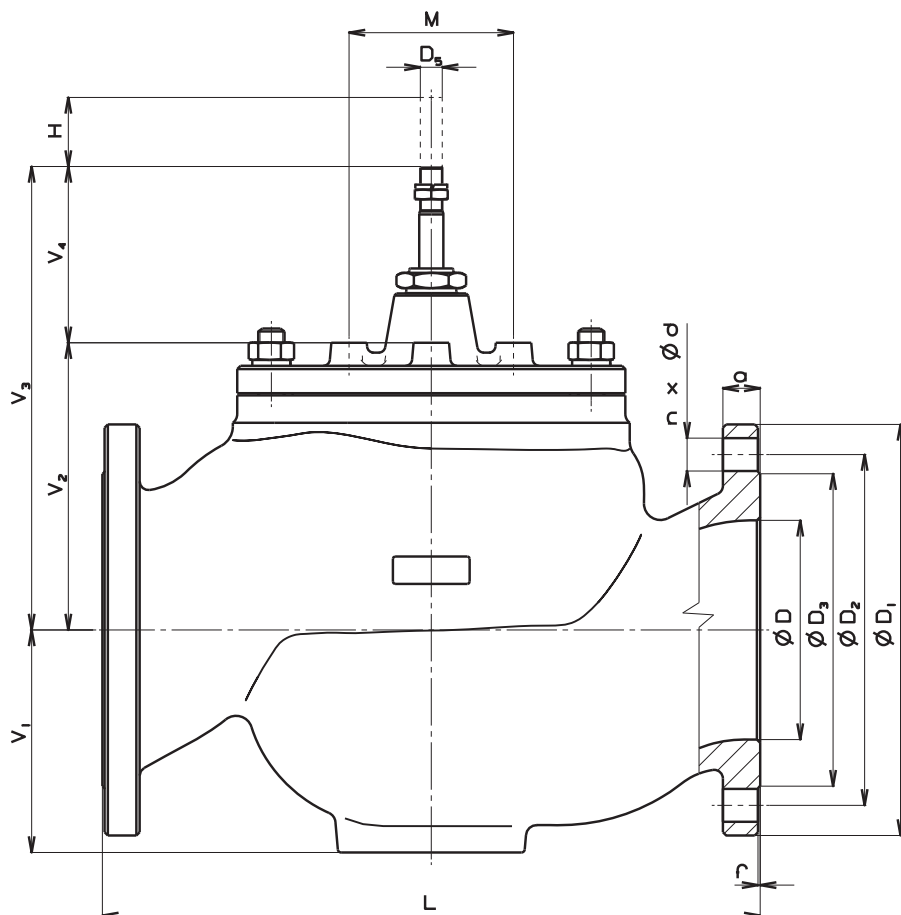



Control valves DN 15 - 400, PN 16, 25 and 40 with pneumatic actuators

Description

Control valves RV 212 (Ex), RV 222 (Ex) and RV 232 (Ex) [further only RV 2x2 (Ex)] are single-seated valves with pressure-balanced plug designed for regulation and shut-off of process medium flow. In regard of used actuators, the valves are suitable for regulation at high differential pressures with low-linear-force actuators. Flow characteristics, Kvs values and leakage rates correspond to international standards.

Valves RV 2x2 (Ex) are especially designed for pneumatic actuators of Flowserve.

Application

The valves series RV 2x2 are designed for applications in heating, ventilation, power generation and chemical processing industries. The valves RV 2x2 Ex meet the requirements II 1/2G IIB acc. to ČSN-EN 13 463-1 (9/2002) and ČSN EN 1127-1 (9/1998), and in connection with suitable actuators, they are also designed for applications in gas and chemical industries. Valve body can be optionally made of spheroidal cast iron, cast steel and stainless steel.

The materials selected correspond to recommendations stipulated by ČSN-EN 1503-1 (1/2002) (steels) and ČSN-EN 1503-3 (1/2002) (cast). The maximal permissible operating pressures in behaviour with types of material and temperature are specified in the table on page 28 of this catalogue.

Process media

Valves series RV 2x2 are designed for regulation of flow and pressure of liquids, gases and vapours without abrasive particles e.g. water, steam, air and other media compatible with material of the valve inner parts. The valves series RV 2x2 Ex are designed also for control and shut-off of the flow and pressure of technical and fuel gases and inflammable liquids. The usage of the valve made of spheroidal cast iron (RV 212) for steam is limited by the following parameters. The steam must be super-heated (its dryness at valve outlet $x_v \geq 0,98$) and inlet pressure $p_i \leq 0,4$ MPa when differential pressure is of above-critical value, and $p_i \leq 1,6$ MPa when differential pressure is of under-critical value. In case these two conditions are not kept, it is necessary to use the valve made of cast steel (RV 222). To ensure a reliable regulation, the producers recommends to pipe a strainer in front of the valve into pipeline or ensure in any other way that process medium does not contain abrasive particles or impurities.

Installation

The valve is to be piped the way so that the direction of medium flow will coincide with the arrows on the body.

The valve can be installed in any position except position when the actuator is under the valve body. When medium temperature exceeds 150°C, it is necessary to protect the actuator against glowing heat from the pipeline e.g. by the means of proper insulating of the pipeline and valve or by tilting the valve away from the heat radiation.

Technical data

Series	RV 212 (Ex)	RV 222 (Ex)	RV 232 (Ex)
Type of valve	Two-way, single-seated, control valve with pressure-balanced plug		
Nominal size range	DN 25 to 400		DN 25 to 400
Nominal pressure	DN 25 to 150; PN 16, 40 DN 200 to 400; PN 16		PN 16, 25, 40
Body material	Spheroidal cast iron EN-JS 1025 (EN-GJS-400-10-LT)	Cast steel 1.0619 (GP240GH) 1.7357 (G17CrMo5-5)	Stainless steel 1.4581 (GX5CrNiMoNb19-11-2)
Seat material: DN 15 - 50	1.4028 / 17 023.6	1.4028 / 17 023.6	1.4571 / 17 348.4
DIN W.Nr./+ČSN DN 80 - 400	1.4027 / 42 2906.5	1.4027 / 42 2906.5	1.4581 / 42 2941.4
Plug material : DN 15 - 65	1.4021 / 17 027.6	1.4021 / 17 027.6	1.4571 / 17 348.4
DIN W.Nr./+ČSN DN 80 - 150	1.4027 / 42 2906.5	1.4027 / 42 2906.5	1.4581 / 42 2941.4
DN 200 - 400	1.4021 / 17 022.6	1.4021 / 17 022.6	1.4581 / 42 2941.4
Operating temperature range	-20 to 260°C	-20 to 260°C	-20 to 260°C
Face to face dimensions	Section 1 acc. to ČSN-EN 558-1 (3/1997)		
Connection flanges	Acc. to ČSN-EN 1092-1 (4/2002)		
Flange face	Type B1 (raised-faced) acc. to ČSN-EN 1092-2 (1/1999)	Type B1 (raised-faced) or Type F (female) or type D (groove) according to ČSN-EN 1092-1 (2/2003)	
Type of plug	V-ported, perforated		
Flow characteristic	Linear, equal-percentage, LDMspline®, parabolic		
Kvs value	4 to 1600 m ³ /hour		
Leakage rate	Class III. acc. to ČSN-EN 1349 (5/2001) (<0.1% Kvs) for c. valves with metal-metal seat sealing Class IV. acc. to ČSN-EN 1349 (5/2001) (<0.01% Kvs) for c. valves with metal-PTFE seat sealing		
Leakage rate Ex	Leakage rate 6 acc. to ČSN 13 3060 - section 2		
Rangeability r	50 : 1		
Packing	O - ring EPDM $t_{max}=140^{\circ}C$, DRSpack® (PTFE) $t_{max}=260^{\circ}C$, Exp. graphite, bellows $t_{max}=260^{\circ}C$		

Kvs values and differential pressures Δp_{max} [MPa] for valves DN 25 to 150 with Flowserve actuators

Δp_{max} value is the valve max. differential pressure when open-close function is always guaranteed. In regard of service life of seat and plug, it is recommended so that permanent

differential pressure would not exceed 1.6 MPa. Otherwise it is suitable to use perforated plug or sealing surfaces of seat and plug with a hard metal overlay.

For further information on actuating, see actuators' catalogue sheets		Pneumatic actuators		PA 127				PB 252						
		Specification No. of actuator		BVCxAA	BVCxZA	BVCxAA	BVCxZA	BVCxAA	BVCxZA	BVCxAA	BVCxZA			
		Actuator function		direct	indirect	direct	indirect	direct	indirect	direct	indirect	direct	indirect	
		Spring range [bar]		1,5 - 2,7	1,5 - 2,7	1,5 - 2,7	1,5 - 2,7	1,5 - 2,7	1,5 - 2,7	1,5 - 2,7	1,5 - 2,7	1,5 - 2,7	1,5 - 2,7	
		Spring setting [bar]		1,5 - 2,46	1,75 - 2,7	1,5 - 2,46	1,75 - 2,7	1,5 - 2,46	1,75 - 2,7	1,5 - 2,46	1,75 - 2,7	1,5 - 2,46	1,75 - 2,7	
		Feeding pressure [bar]		4,0	4,5	4,0	4,5	4,0	4,5	4,0	4,5	4,0	4,5	
		Marking in valve specification No.		PFF				PFA						
		Linear force		1,87 kN	2,18 kN	3,7 kN	4,35 kN	1,87 kN	2,18 kN	3,7 kN	4,35 kN	1,87 kN	2,18 kN	
		Kvs [m ³ /h]		Δp_{max}		Δp_{max}		Δp_{max}		Δp_{max}		Δp_{max}		
DN	H	1	2	3	4	5	metal	PTFE	metal	PTFE	metal	PTFE	metal	PTFE
25	16	10	6,3 ¹⁾	4,0 ¹⁾	2,5 ¹⁾	1,6 ¹⁾	4.00	4.00	4.00	4.00	4.00	4.00	4.00	4.00
32		16	10	6,3 ¹⁾	4,0 ¹⁾	2,5 ¹⁾	4.00	4.00	4.00	4.00	4.00	4.00	4.00	4.00
40		25	16	10	6,3 ¹⁾	4,0 ¹⁾	2,5 ¹⁾	4.00	4.00	4.00	4.00	4.00	4.00	4.00

For further information on actuating, see actuators' catalogue sheets		Pneumatic actuators		PB 502				PB 502						
		Specification No. of actuator		BVCxAB	BVCxZB	BVCxAB	BVCxZB	BVCxAB	BVCxZB	BVCxAB	BVCxZB			
		Actuator function		direct	indirect	direct	indirect	direct	indirect	direct	indirect	direct	indirect	
		Spring range [bar]		1,5 - 2,7	1,5 - 2,7	1,5 - 2,7	1,5 - 2,7	1,5 - 2,7	1,5 - 2,7	1,5 - 2,7	1,5 - 2,7	1,5 - 2,7	1,5 - 2,7	
		Spring setting [bar]		1,5 - 2,25	1,95 - 2,7	1,5 - 2,7	1,95 - 2,7	1,5 - 2,7	1,95 - 2,7	1,5 - 2,7	1,95 - 2,7	1,5 - 2,7	1,95 - 2,7	
		Feeding pressure [bar]		3,8	4,7	3,8	4,7	3,8	4,7	3,8	4,7	3,8	4,7	
		Marking in valve specification No.		PFB				PFB						
		Linear force		7,5 kN	9,75 kN	7,5 kN	9,75 kN	7,5 kN	9,75 kN	7,5 kN	9,75 kN	7,5 kN	9,75 kN	
		Kvs [m ³ /h]		Δp_{max}		Δp_{max}		Δp_{max}		Δp_{max}		Δp_{max}		
DN	H	1	2	3	4	5	metal	PTFE	metal	PTFE	metal	PTFE	metal	PTFE
50	25	40	25	16	10	6,3 ¹⁾	4.00	4.00	4.00	4.00	---	---	---	---
65		63	40	25	16	10	4.00	4.00	4.00	4.00	---	---	---	---
80	40	100	63	40	25	16	---	---	---	---	4.00	4.00	4.00	4.00
100		160	100	63	40	25	---	---	---	---	4.00	4.00	4.00	4.00
125		250	160	100	63	40	---	---	---	---	4.00	4.00	4.00	4.00
150		360	250	160	100	63	---	---	---	---	4.00	4.00	4.00	4.00

Kvs values and differential pressures Δp_{max} [MPa] for valves DN 200 to 400 with Flowserve actuators

Δp_{max} value is the valve max. differential pressure when open-close function is always guaranteed. In regard of service life of seat and plug, it is recommended so that permanent

differential pressure would not exceed 1.6 MPa. Otherwise it is suitable to use perforated plug or sealing surfaces of seat and plug with a hard metal overlay.

For further information on actuating, see actuators' catalogue sheets		Pneumatic actuators		PO 1502										
		Specification No. of actuator		BVCxAD	BVCxZD	BFSxAD	BFSxZD	BDYxAE	BFYxZE					
		Actuator function		direct	indirect	direct	indirect	direct	direct					
		Spring range [bar]		1,5 - 2,7	1,5 - 2,7	2,0 - 3,5	2,0 - 3,5	1,0 - 2,4	2,0 - 4,8					
		Spring setting [bar]		1,5 - 2,7	1,5 - 2,7	2,0 - 3,5	2,0 - 3,5	1,0 - 2,4	2,0 - 4,8					
		Feeding pressure [bar]		4,2	4,2	5,5	5,5	4,5	5,8					
		Marking in valve specification No.		PFD										
		Linear force		22,5 kN	22,5 kN	30 kN	30 kN	30 kN	30 kN					
		Kvs [m ³ /h]		packing	packing	packing	packing	packing	packing					
DN	Ds	H	1	2	3	4	5	graphitPTFE	graphitPTFE	graphitPTFE	graphitPTFE	graphitPTFE	graphitPTFE	
200	200	80	570	400	250	160	100	4.00	4.00	4.00	4.00	---	---	
250	230		800	630	400	250	160	4.00	4.00	4.00	4.00	4.00	---	---
300	250		1000	800	630	400	250	4.00	4.00	4.00	4.00	4.00	---	---
400	330		1000	1000	630	400	250	---	---	---	---	4.00	4.00	4.00

¹⁾ Linear characteristic only

Perforated plugs is not possible to delivery for Kvs acc. to column No.1, for Kvs acc. to column No. 2 with linear or parabolic characteristic only. For another columns without limitation.

Max. differential pressures are valid for metal-metal seat sealing and for hard metal overlay on sealing surfaces.

Max. differential pressure Δp for valves PN 16 (PN 25) must be 1,6 MPa (2,5 MPa).

Dimensions and weights of valves made of spheroidal cast iron RV 212 (Ex) DN 25 to 150

DN	PN 16					PN 40					PN 16, PN 40												
	D ₁	D ₂	D ₃	d	n	D ₁	D ₂	D ₃	d	n	D	f	D ₄	D ₅	L	V ₁	V ₂	*V ₂	V ₃	*V ₃	a	m	*m _v
	mm	mm	mm	mm		mm	mm	mm	mm		mm	mm	mm	mm	mm	mm	mm	mm	mm	mm	mm	kg	kg
25	115	85	65	14	4	115	85	65	14	4	25	3	65	M10x1	160	58	100	267	230	397	16	7	3.5
32	140	100	76	140		100	76	32	180		70				100	267	230	397	18	8.5	3.5		
40	150	110	84	150		110	84	40	200		75				100	267	230	397	19	8.5	3.5		
50	165	125	99	165		125	99	50	230		85				132	339	262	469	19	14.5	4		
65	185	145	118	185	145	118	65	290	93	132	339	262	469	19	18.5	4							
80	200	160	132	200	160	132	80	M16x1,5	310	105	164	482	294	612	19	27.5	4.5						
100	220	180	156	235	190	156	23		8	100	118	164	482	294	612	19	39	4.5					
125	250	210	184	270	220	184	28		125	135	183	501	313	631	23.5	60	5						
150	285	240	211	300	250	211	28		150	150	200	518	330	648	26	81	5						

Dimensions and weights of valves made of cast steel and stainless steel for the type RV 222 (Ex), RV 232 (Ex) DN 25 to 150

DN	PN 16					PN 40					PN 16, PN 40												
	D ₁	D ₂	D ₃	d	n	D ₁	D ₂	D ₃	d	n	D	f	D ₄	D ₅	L	V ₁	V ₂	*V ₂	V ₃	*V ₃	a	m	*m _v
	mm	mm	mm	mm		mm	mm	mm	mm		mm	mm	mm	mm	mm	mm	mm	mm	mm	mm	mm	kg	kg
25	115	85	68	14	4	115	85	68	14	4	25	2	65	M10x1	160	58	100	267	230	397	18	8.5	3.5
32	140	100	78	140		100	78	32	180		70				100	267	230	397	18	10	3.5		
40	150	110	88	150		110	88	40	200		75				100	267	230	397	18	10	3.5		
50	165	125	102	165		125	102	50	230		85				132	339	262	469	20	21	4		
65	185	145	122	185	145	122	65	290	93	132	339	262	469	22	27	4							
80	200	160	138	200	160	138	80	M16x1,5	310	105	164	482	294	612	24	42	4.5						
100	220	180	158	235	190	162	22		8	100	118	164	482	294	612	24	50	4.5					
125	250	210	188	270	220	188	26		125	135	183	501	313	631	26	84	5						
150	285	240	212	300	250	218	26		150	150	200	518	330	648	28	103	5						

- ¹⁾ - with regard of the standard previously in force, there is an option to have the number of connection bolts as stipulated in ČSN-EN 1092- - for valve with bellows packing
m_v - weight to be added to weight of valve if equipped with bellows packing

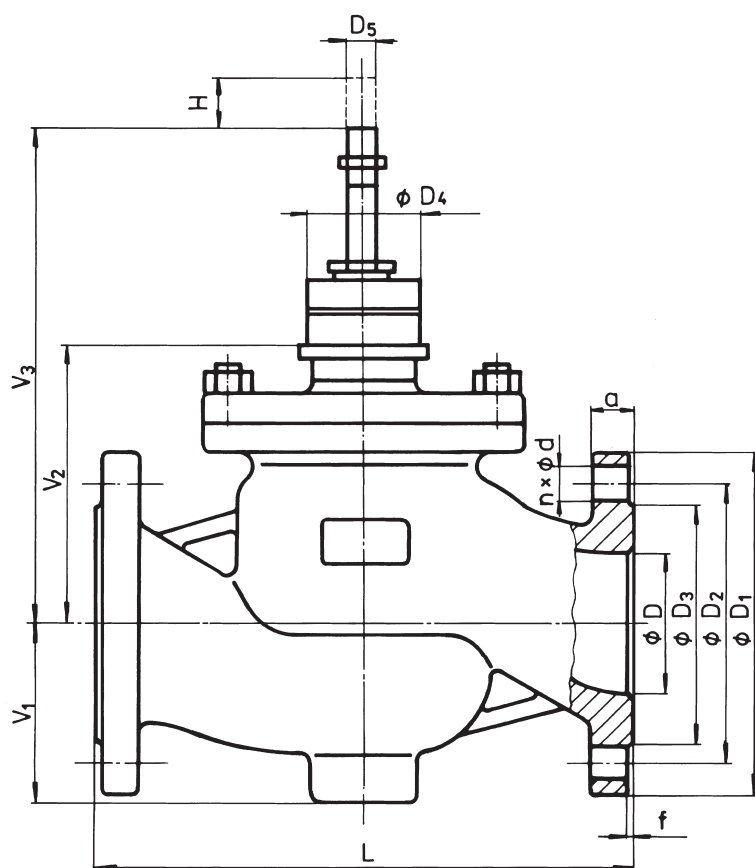

Dimensions and weights of valves made of spheroidal cast iron RV 212 (Ex), DN 200 to 400

DN	PN 16																	
	D ₁	D ₂	D ₃	d	n	a	D	D ₅	M	L	V ₁	V ₂	V ₃	V ₄	f	H	m	
	mm	mm	mm	mm		mm	mm	mm	mm	mm	mm	mm	mm	mm	mm	mm	mm	kg
200	340	295	266	23	12	20	200	M20x1.5	150	600	203	262	422	160	3	80	153	
250	405	355	319	28		22	250			730	253	346	506		3		264	
300	460	410	370	24.5		300	850			296	395	555	4		390			
400	580	525	480	31	16	28	400			1100	382	512	672		4	100	790	

Dimensions and weights of valves made of cast steel and stainless steel for the type RV 222 (Ex), RV 232 (Ex), DN 200 to 400

DN	PN 16						PN 25						PN 40					
	D ₁	D ₂	D ₃	d	n	a	D ₁	D ₂	D ₃	d	n	a	D ₁	D ₂	D ₃	d	n	a
	mm	mm	mm	mm		mm	mm	mm	mm	mm		mm	mm	mm	mm	mm		mm
200	340	295	268	22	12	24	360	310	278	26	12	30	375	320	285	30	12	34
250	405	355	320	26		26	425	370	335	30		32	450	385	345	33		38
300	460	410	378	28		28	485	430	395	30	34	515	450	410	33	42		
400	580	525	490	30	16	32	620	550	505	36	16	40	660	585	535	39	16	50

DN	PN 16, 25, 40										
	D	D ₅	M	L	V ₁	V ₂	V ₃	V ₄	f	H	m
	mm	mm	mm	mm	mm	mm	mm	mm	mm	mm	kg
200	200	M20x1.5	150	600	203	262	422	160	2	80	232
250	250			730	253	346	506				395
300	300			850	296	395	555				596
400	400			1100	382	512	672				1213

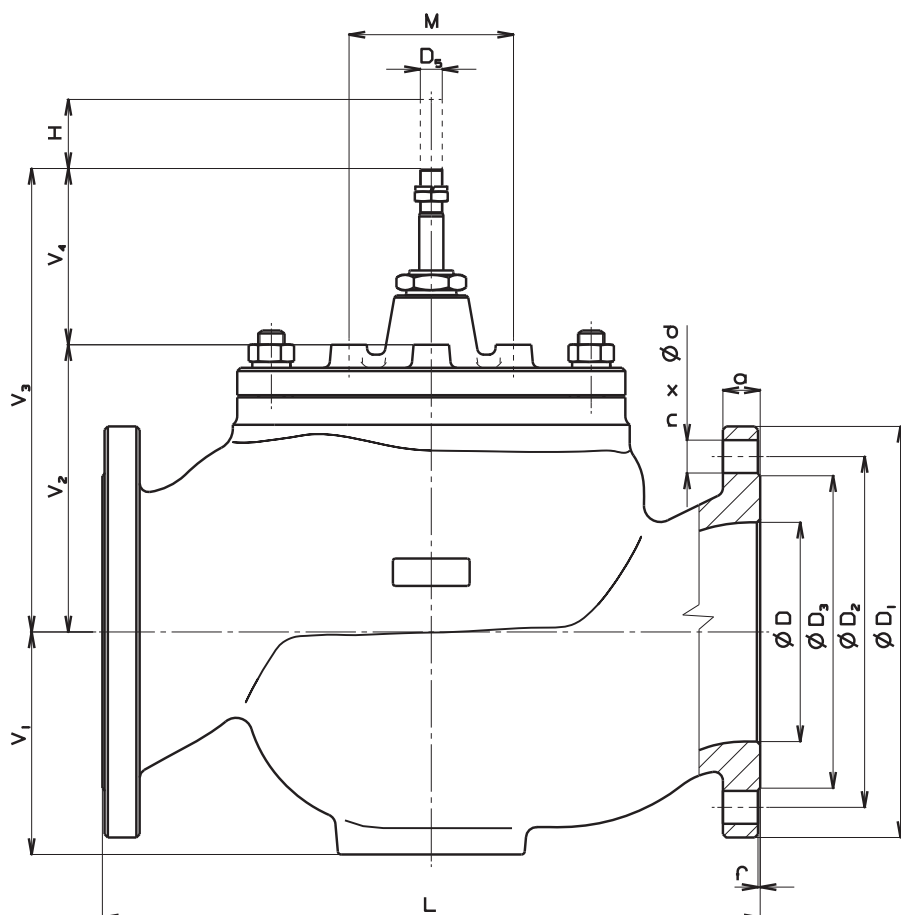



Control valves DN 15 - 300, PN 16, 25 and 40 with pneumatic actuators

Description

Control valves RV 214 (Ex), RV 224 (Ex) and RV 234 (Ex) (further only RV 2x4) are three-way valves with mixing or flow-diverting function. In regard of a great variety of used actuators, the valves are suitable for regulation at low as well as high differential pressures in a diversity of operating conditions. Flow characteristics, Kvs values and leakage rates correspond to international standards.

Valves RV 2x4 are especially designed for pneumatic actuators of Flowserve.

Application

These valves have a wide range of application in heating, ventilation, power generation and chemical processing industries. Valves RV 2x4 Ex meet demands II 1/2G IIB acc. to ČSN-EN 13463-1 (9/2002) and ČSN EN 1127-1 (9/1998) and in connection with suitable actuators are designed for application in gasworks and chemical processing industries. Valve body can be optionally made of spheroidal cast iron, cast steel and austenitic stainless steel according to operating conditions.

The materials selected correspond to recommendations stipulated by ČSN-EN 1503-1 (1/2002) (steels) and ČSN-EN 1503-3 (1/2002) (cast). The maximal permissible operating pressures in behaviour with types of material and temperature are specified in the table on page 28 of this catalogue.

Process media

Valves series RV 2x4 are designed for regulation of flow and pressure of liquids, gases and vapours without abrasive particles e.g. water, steam, air and other media compatible with material of the valve inner parts. Valves of RV 2x4 series are also designed for regulation of flow and pressure of technical gases and flammable liquids. The usage of the valve made of spheroidal cast iron (RV 214) for steam is limited by the following parameters. The steam must be superheated (its dryness at valve outlet $x \geq 0,98$) and inlet pressure $p_i \leq 0,4$ MPa when differential pressure is of above-critical value, and $p_i \leq 1,6$ MPa when differential pressure is of under-critical value. In case these two conditions are not kept, it is necessary to use the valve made of cast steel (RV 224). To ensure a reliable regulation, the producers recommends to pipe a strainer in front of the valve into pipeline or ensure in any other way that process medium does not contain abrasive particles or impurities.

Installation

When the valve is used as mixing, it must be piped the way so that direction of process medium flow will coincide with the arrows on the body (inlet ports A, B and outlet port AB). When the valves is used as diverting, process medium flows through common valve port AB and split streams leave through valve ports A and B.). The valve can be installed in any position except position when the actuator is under the valve body. When medium temperature exceeds 150°C, it is necessary to protect the actuator against glowing heat from the pipeline; e.g. by the means of proper insulating of the pipeline and valve or by fitting the valve away from the heat radiation.

Technical data

Series	RV 214 (Ex)	RV 224 (Ex)	RV 234 (Ex)
Type of valve	Three-way control valve		
Nominal size range	DN 15 to 300		
Nominal pressure	DN 15 to 150: PN 16, 40 DN 200 to 300: PN 16	PN 16, 25 a 40	
Body material	Spheroidal cast iron EN-JS 1025 (EN-GJS-400-10-LT)	Cast steel 1.0619 (GP240GH) 1.7357 (G17CrMo5-5)	Stainless steel 1.4581 (GX5CrNiMoNb19-11-2)
Seat material: DN 15 - 50	1.4028 / 17 023.6	1.4028 / 17 023.6	1.4571 / 17 348.4
DIN W.Nr./ČSN DN 80 - 300	1.4027 / 42 2906.5	1.4027 / 42 2906.5	1.4581 / 42 2941.4
Plug material : DN 15 - 65	1.4021 / 17 027.6	1.4021 / 17 027.6	1.4571 / 17 348.4
DIN W.Nr./ČSN DN 80 - 150	1.4027 / 42 2906.5	1.4027 / 42 2906.5	1.4581 / 42 2941.4
DN 200 - 300	1.4021 / 17 022.6	1.4021 / 17 022.6	1.4581 / 42 2941.4
Operating temperature range	-20 až 300°C	-20 až 500°C	-20 až 400°C
Face to face dimensions	Section 1 acc. to ČSN-EN 558-1 (3/1997)		
Connection flanges	Acc. to ČSN-EN 1092-1 (4/2002)		
Flange face	Type B1 (raised-faced) acc. to ČSN-EN 1092-2 (1/1999)	Type B1 (raised-faced) or Type F (female) or type D (groove) according to ČSN-EN 1092-1 (2/2003)	
Type of plug	V-ported, perforated		
Flow characteristic	Linear, equal-percentage, in direct way		
Kvs value	1.6 to 1000 m ³ /h		
Leakage rate	Class III. acc. to ČSN-EN 1349 (5/2001) (<0.1% Kvs) for c. valves with metal-metal seat sealing Class IV. acc. to ČSN-EN 1349 (5/2001) (<0.01% Kvs) for c. valves with metal-PTFE seat sealing		
Leakage rate Ex	Leakage rate 6 acc. to ČSN 13 1060 - section 2		
Rangeability r	50 : 1		
Packing	O - ring EPDM $t_{max}=140^{\circ}\text{C}$, DRSpack® (PTFE) $t_{max}=260^{\circ}\text{C}$, Exp. graphite, bellows $t_{max}=500^{\circ}\text{C}$		

Kvs values and differential pressures Δp_{max} Pa for valves D to with Flowserve actuators - mi ng function flow direction elow plug

Δp_{max} value is the valve max. differential pressure when open-close function is always guaranteed. In regard of service life of seat and plug, it is recommended so that permanent

differential pressure would not exceed 1.6 MPa. Otherwise it is suitable to use perforated plug or sealing surfaces of seat and plug with a hard metal overlay.

For further information on actuating, see actuators' catalogue sheets		Pneumatic actuators		PA 127				PA 252				
		Spec. No. of actuator		BVCxAA		BVCxZA		BVCxAA		BVCxZA		
		Actuator function		direct		indirect		direct		indirect		
		Spring range [bar]		1,5 - 2,7		1,5 - 2,7		1,5 - 2,7		1,5 - 2,7		
		Spring setting [bar]		1,5 - 2,46		1,75 - 2,7		1,5 - 2,46		1,75 - 2,7		
		Feeding pressure [bar]		4		4,5		4		4,5		
		Mark. in valve spec. No.		PFF				PFA				
		Linear force [kN]		1,87 kN		2,18 kN		3,7 kN		4,3 kN		
Kvs [m ³ /h]		Δp_{max}		Δp_{max}		Δp_{max}		Δp_{max}				
DN	H	1	2	3	metal	PTFE	metal	PTFE	metal	PTFE	metal	PTFE
15	16	---	2.5 ¹⁾	1.6 ¹⁾	4.00	---	4.00	---	4.00	---	4.00	---
15		4.0 ¹⁾	---	---	4.00	---	4.00	---	4.00	---	4.00	---
20		---	---	2.5 ¹⁾	4.00	---	4.00	---	4.00	---	4.00	---
20		---	4.0 ¹⁾	---	4.00	---	4.00	---	4.00	---	4.00	---
20		6.3 ¹⁾	---	---	3.38	---	4.00	---	4.00	---	4.00	---
25		10	6.3 ²⁾	4.0 ²⁾	2.01	2.42	2.57	2.98	4.00	4.00	4.00	4.00
32		16.0	10.0	6.3 ²⁾	1.14	1.45	1.48	1.80	3.16	3.48	3.82	4.00
40		25.0	16.0	10.0	0.67	0.93	0.89	1.15	1.97	2.23	2.40	2.66

For further information on actuating, see actuators' catalogue sheets		Pneumatic actuators		PB 502				PB 700							
		Spec. No. of actuator		BVCxAB		BVCxZB		BVCxZB		BVCxZB		BVCxZB			
		Actuator function		direct		indirect		direct		indirect		direct		indirect	
		Spring range [bar]		1,5 - 2,7		1,5 - 2,7		1,5 - 2,7		1,5 - 2,7		1,5 - 2,7		1,5 - 2,7	
		Spring setting [bar]		1,5 - 2,25		1,95 - 2,7		1,5 - 2,7		1,5 - 2,7		1,5 - 2,7		1,5 - 2,7	
		Feeding pressure [bar]		3,8		4,7		4,2		4,2		4,2		4,2	
		Mark. in valve spec. No.		PFB				PFC							
		Linear force [kN]		7,5 kN		9,7 kN		7,5 kN		7,5 kN		10,5 kN		10,5 kN	
Kvs [m ³ /h]		Δp_{max}		Δp_{max}		Δp_{max}		Δp_{max}		Δp_{max}		Δp_{max}			
DN	H	1	2	3	metal	PTFE	metal	PTFE	metal	PTFE	metal	PTFE			
50	25	40	25	16	2.76	2.95	3.69	3.88	---	---	---	---			
65		63	40	25	1.65	1.80	2.22	2.37	---	---	---	---			
80	40	100	63	40	---	---	---	---	1.01	1.13	1.01	1.13			
100		160	100	63	---	---	---	---	0.63	0.73	0.63	0.73			
125		250	160	100	---	---	---	---	0.39	0.47	0.39	0.47			
150		360	250	160	---	---	---	---	0.26	0.33	0.26	0.33			

1) parabolic plug in straight way, V-ported plug in angle way
2) V-ported plug in angle way, in straight way V-ported plug for linear characteristic and for equal-percentage characteristic parabolic plug

Bellows packing can be used for DN 15 and 20 and for DN above 200.

metal - version with metal - metal seat sealing
PTFE - version with metal - PTFE seat sealing (is not applicable to contoured plugs)

Max. differential pressures specified in table apply to PTFE and O-ring packing. Δp_{max} for bellows must be consulted with the producer. It applies to graphite packing as well especially when required Δp value is close to max. values specified in table. It applies to graphite packing as well especially when required Δp value is close to max. values specified in table.

Kvs values and differential pressures Δp_{\max} Pa for valves D to with Flowserve actuators - flow-diverting function flow direction above plug

Δp_{\max} value is the valve max. differential pressure when open-close function is always guaranteed.

For further information on actuating, see actuators' catalogue sheets		Pneumatic actuators		PA 252		
		Specification No. of actuator	BVCxAA	BVCxZA		
		Actuator function	direct	indirect		
		Spring range [bar]	1,5 - 2,7	1,5 - 2,7		
		Spring setting [bar]	1,5 - 2,46	1,75 - 2,7		
		Feeding pressure [bar]	4	4,5		
		Marking in valve specification No.	PFA			
		Linear force	3,7 kN	4,35 kN		
		Kvs [m ³ /h]		packing	packing	
DN	H	1	2	3	graphit	PTFE
15	16	---	2.5 ¹⁾	1.6 ¹⁾	1.76	4.00
15		4.0 ¹⁾	---	---	1.76	4.00
20		---	---	4.0 ¹⁾	0.88	2.14
20		---	4.0 ¹⁾	---	0.88	2.14
20		6.3 ¹⁾	---	---	0.88	2.14
25		10	6.3 ²⁾	4.0 ²⁾	0.55	1.33
32		16	10	6.3 ²⁾	0.33	0.80
40		25	16	10	0.21	0.52

For further information on actuating, see actuators' catalogue sheets		Pneumatic actuators		PB 502				PB 700	
		Specification No. of actuator	BVCxAB	BVCxZB	BVCxZB	BVCxZB	BVCxAB	BVCxZB	
		Actuator function	přímá	nepřímá	přímá	nepřímá	přímá	nepřímá	
		Spring range [bar]	1,5 - 2,7	1,5 - 2,7	1,5 - 2,7	1,5 - 2,7	1,5 - 2,7	1,5 - 2,7	
		Spring setting [bar]	1,5 - 2,25	1,95 - 2,7	1,5 - 2,7	1,5 - 2,7	1,5 - 2,7	1,5 - 2,7	
		Feeding pressure [bar]	3,8	4,7	4,2	4,2	4,2	4,2	
		Marking in valve specification No.	PFB				PFC		
		Linear force	7,5 kN	9,75 kN	7,5 kN	7,5 kN	10,5 kN	10,5 kN	
		Kvs [m ³ /h]		ucpávka	ucpávka	ucpávka	ucpávka	ucpávka	
DN	H	1	2	3	grafit	PTFE	grafit	PTFE	
50	25	40	25	16	0.45	0.63	0.64	0.82	
65		63	40	25	0.28	0.39	0.39	0.50	
80	40	100	63	40	---	---	0.18	0.27	
100		160	100	63	---	---	0.11	0.17	
125		250	160	100	---	---	0.07	0.11	
150		360	250	160	---	---	0.05	0.08	

- 1) parabolic plug in straight way, V-ported plug in angle way
- 2) V-ported plug in angle way, in straight way for linear characteristic V-ported plug and for equal-percentage characteristic parabolic plug.

Bellows packing can be used for DN 15 and 20 and for DN above 200.

Max. differential pressure Δp for valves PN 16 must be 1.6 MPa.

metal - version with metal - metal seat sealing

PTFE - version with metal - PTFE seat sealing (is not applicable to contoured plugs)

Max. differential pressures specified in table apply to **PTFE and graphite packing**. Δp_{\max} for bellows must be consulted with the producer.

Values are valid for all executions of seat sealings.

Kvs values and differential pressures Δp_{max} Pa for valves D to with Flowserve actuators - mixing function flow direction below plug

Δp_{max} value is the valve max. differential pressure when open-close function is always guaranteed.

For further information on actuating, see actuators' catalogue sheets			Pneumatic actuators		PO 1502				PO 3002				
			Specification No. of actuator	BVCxAD	BVCxZD	BGFxAD	BFSxZD	BEPxAD	BEPxZD				
			Actuator function	direct	indirect	direct	indirect	direct	indirect				
			Spring range [bar]	1,5 - 2,7	1,5 - 2,7	2,0 - 3,5	2,0 - 3,5	1,3 - 2,1	1,3 - 2,1				
			Spring setting [bar]	1,5 - 2,7	1,5 - 2,7	2,0 - 3,5	2,0 - 3,5	1,3 - 2,1	1,3 - 2,1				
			Feeding pressure [bar]	4,2	4,2	5,5	5,5	3,4	3,4				
			Marking in valve specification No.	PFD				PFE					
			Linear force	22,5 kN	22,5 kN	30 kN	30 kN	39 kN	39 kN				
			Kvs [m ³ /h]					packing	packing	packing	packing	packing	packing
DN	Ds	H	1	2	3	4	5	graphitPTFE	graphitPTFE	graphitPTFE	graphitPTFE	graphitPTFE	graphitPTFE
200	200	80	570	400	250	160	100	0.48 0.57	0.48 0.57	0.71 0.80	0.71 0.80	0.99 1.07	0.99 1.07
250	230		800	630	400	250	160	0.33 0.41	0.33 0.41	0.51 0.58	0.51 0.58	0.72 0.79	0.72 0.79
300	250		1000	800	630	400	250	0.28 0.34	0.28 0.34	0.43 0.49	0.43 0.49	0.60 0.67	0.60 0.67

Max. differential pressures are valid for metal-metal seat sealing and for hard metal overlay on sealing surfaces.

Kvs values and differential pressures Δp_{max} Pa for valves D to with Flowserve actuators - flow-diverting function flow direction above plug

Δp_{max} value is the valve max. differential pressure when open-close function is always guaranteed.

For further information on actuating, see actuators' catalogue sheets			Pneumatic actuators		PO 1502				PO 3002				
			Specification No. of actuator	BVCxAD	BVCxZD	BGFxAD	BFSxZD	BEPxAD	BEPxZD				
			Actuator function	direct	indirect	direct	indirect	direct	indirect				
			Spring range [bar]	1,5 - 2,7	1,5 - 2,7	2,0 - 3,5	2,0 - 3,5	1,3 - 2,1	1,3 - 2,1				
			Spring setting [bar]	1,5 - 2,7	1,5 - 2,7	2,0 - 3,5	2,0 - 3,5	1,3 - 2,1	1,3 - 2,1				
			Feeding pressure [bar]	4,2	4,2	5,5	5,5	3,4	3,4				
			Marking in valve specification No.	PFD				PFE					
			Linear force	22,5 kN	22,5 kN	30 kN	30 kN	39 kN	39 kN				
			Kvs [m ³ /h]					packing	packing	packing	packing	packing	packing
DN	Ds	H	1	2	3	4	5	graphitPTFE	graphitPTFE	graphitPTFE	graphitPTFE	graphitPTFE	graphitPTFE
200	200	80	570	400	250	160	100	0.12 0.14	0.12 0.14	0.16 0.18	0.16 0.18	0.22 0.24	0.22 0.24
250	230		800	630	400	250	160	0.09 0.10	0.09 0.10	0.12 0.14	0.12 0.14	0.17 0.18	0.17 0.18
300	250		1000	800	630	400	250	0.08 0.09	0.08 0.09	0.10 0.12	0.10 0.12	0.14 0.15	0.14 0.15

Max. differential pressures are valid for metal-metal seat sealing and for hard metal overlay on sealing surfaces.

Dimensions and weights of valves made of spheroidal cast iron RV 214 (Ex), DN 15 to 150

DN	PN 16					PN 40					PN 16, PN 40												
	D ₁	D ₂	D ₃	d	n	D ₁	D ₂	D ₃	d	n	D	f	D ₄	D ₅	L	V ₁	V ₂	*V ₂	V ₃	*V ₃	a	m	*m _v
	mm	mm	mm	mm		mm	mm	mm	mm		mm	mm	mm	mm	mm	mm	mm	mm	mm	mm	mm	kg	kg
15	95	65	46	14	4	95	65	46	14	4	15	2	65	M10x1	130	110	67	---	197	---	14	5.5	3.5
20	105	75	56			105	75	56			20				150	115	67	---	197	---	16	6.5	3.5
25	115	85	65			115	85	65			25				160	130	72	239	202	369	16	8.3	3.5
32	140	100	76			140	100	76			32				180	135	72	239	202	369	18	10.5	3.5
40	150	110	84	19	8	150	110	84	19	8	40	3	65	M16x1,5	200	140	72	239	202	369	19	12	3.5
50	165	125	99			165	125	99			50				230	175	92	299	222	429	19	17	4
65	185	145	118			185	145	118			65				290	180	92	299	222	429	19	22	4
80	200	160	132			200	160	132			80				310	220	123	441	253	571	19	31	4.5
100	220	180	156	23	8	235	190	156	23	8	100				350	230	123	441	253	571	19	44	4.5
125	250	210	184			270	220	184			125				400	260	151	469	281	599	23.5	65	5
150	285	240	211			300	250	211			150				480	290	151	469	281	599	26	94	5

Dimensions and weights of valves made of cast steel and stainless steel for the type RV 224 (Ex), RV 234 (Ex) DN 15 to 150

DN	PN 16					PN 40					PN 16, PN 40												
	D ₁	D ₂	D ₃	d	n	D ₁	D ₂	D ₃	d	n	D	f	D ₄	D ₅	L	V ₁	V ₂	*V ₂	V ₃	*V ₃	a	m	*m _v
	mm	mm	mm	mm		mm	mm	mm	mm		mm	mm	mm	mm	mm	mm	mm	mm	mm	mm	mm	kg	kg
15	95	65	45	14	4	95	65	45	14	4	15	2	65	M10x1	130	110	67	---	197	---	16	6	3.5
20	105	75	58			105	75	58			20				150	115	67	---	197	---	18	7	3.5
25	115	85	68			115	85	68			25				160	130	72	239	202	369	18	9.5	3.5
32	140	100	78			140	100	78			32				180	135	72	239	202	369	18	12	3.5
40	150	110	88	18	8	150	110	88	18	8	40	2	65	M16x1,5	200	140	72	239	202	369	18	13.5	3.5
50	165	125	102			165	125	102			50				230	175	92	299	222	429	20	24	4
65	185	145	122			185	145	122			65				290	180	92	299	222	429	22	31	4
80	200	160	138			200	160	138			80				310	220	123	441	253	571	24	43	4.5
100	220	180	158	22	8	235	190	162	22	8	100				350	230	123	441	253	571	24	55	4.5
125	250	210	188			270	220	188			125				400	260	151	469	281	599	26	90	5
150	285	240	212			300	250	218			150				480	290	151	469	281	599	28	120	5

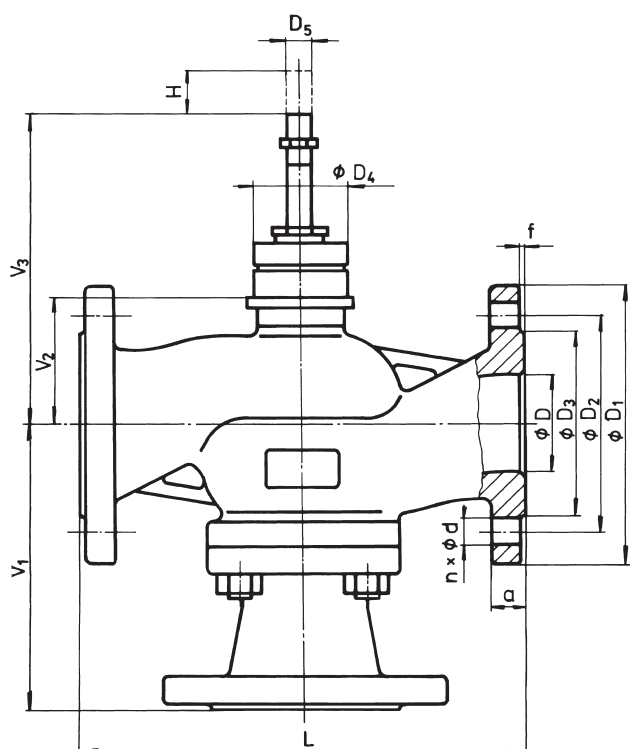

¹⁾ - with regard of the standard previously in force, there is an option to have the number of connection bolts as stipulated in ČSN-EN 1092- - for valve with bellows packing
 m_v - weight to be added to weight of valve if equipped with bellows packing

Dimensions and weights of valves made of spheroidal cast iron RV 214 (Ex), DN 200 to 300

DN	PN 16																	
	D ₁	D ₂	D ₃	d	n	a	D	D ₅	M	L	V ₁	V ₂	V ₃	V ₄	f	H	m	
	mm	mm	mm	mm		mm	mm	mm	mm	mm	mm	mm	mm	mm	mm	mm	mm	kg
200	340	295	266	23	12	20	200	M20x1.5	150	600	400	265	425	160	3	80	162	
250	405	355	319	28		22	250			730	480	360	520		3		280	
300	460	410	370	24.5		300	850			560	402	562	4		410			

Dimensions and weights of valves made of cast steel and stainless steel for the type RV 224, 234 (Ex), DN 200 to 300

DN	PN 16							PN 25					PN 40					
	D ₁	D ₂	D ₃	d	n	a	D ₁	D ₂	D ₃	d	n	a	D ₁	D ₂	D ₃	d	n	a
	mm	mm	mm	mm		mm	mm	mm	mm	mm		mm	mm	mm	mm	mm		mm
200	340	295	268	22	12	24	360	310	278	26	12	30	375	320	285	30	12	34
250	405	355	320	26		26	425	370	335	30		32	450	385	345	33		38
300	460	410	378	26		28	485	430	395	30	16	34	515	450	410	33	16	42

DN	PN 16, 25, 40										
	D	D ₅	M	L	V ₁	V ₂	V ₃	V ₄	f	H	m
	mm	mm	mm	mm	mm	mm	mm	mm	mm	mm	kg
200	200	M20x1.5	150	600	400	265	425	160	2	80	250
250	250			730	480	360	520				425
300	300			850	560	402	562				640

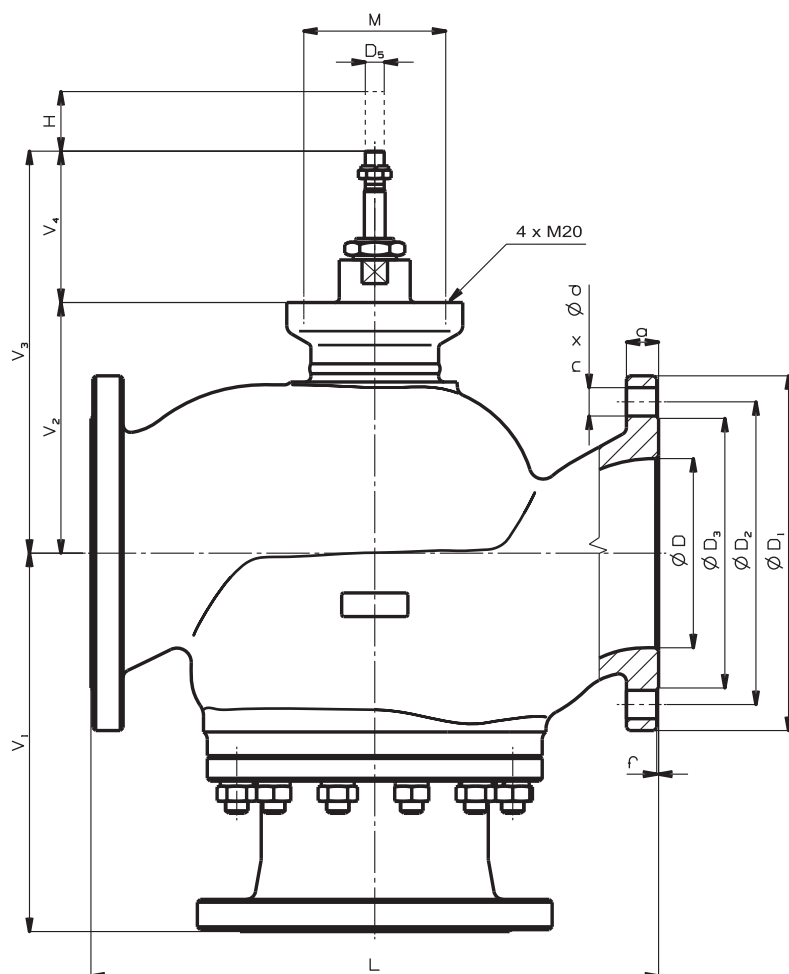

Valve complete specification No. for ordering RV / UV 2x0 (Ex), RV 2x2 (Ex), RV 2x4 (Ex)

		XX	XXX	XXX	XXXX	XX	-XX	/XXX	-XXX	XX
1. Valve	Control valve	RV								
	Shut-off valve	UV								
2. Series ²⁾ For DN 200 to 400 PN 16 only	Valves made of spheroidal cast iron EN-JS 1025 ²⁾	2 1								
	Valves made of cast steel 1.0619, 1.7357	2 2								
	Valves made of stainless steel 1.4581	2 3								
	Direct valve	0								
	Pressure-balanced, direct valve	2								
	Mixing (diverting) valve	4								
3. Actuating	Pneumatic actuator			P						
	Pneu. actuator Flowserve PA 127			P F F						
	Pneu. actuator Flowserve PA 252			P F A						
	Pneu. actuator Flowserve PB 502			P F B						
	Pneu. actuator Flowserve PB 700			P F C						
	Pneu. actuator Flowserve PO 1502			P F D						
	Pneu. actuator Flowserve PO 3002			P F E						
4. Connection	Raised flange				1					
	Female flange				2					
	Groove flange				3					
5. Body material <i>(Operating temperature ranges are specified in parentheses)</i>	Cast steel 1.0619 (-20 to 400°C)				1					
	Spher. cast iron EN-JS 1025 (-20 to 300°C)				4					
	CrMo steel 1.7357 (-20 to 500°C)				7					
	Stainless steel 1.4581 (-20 to 400°C)				8					
	Other material on request				9					
6. Seat sealing ¹⁾ From DN 25; $t_{max} = 260^{\circ}C$	Metal - metal				1					
	Soft sealing (metal - PTFE) ¹⁾				2					
	Hard metal overlay on sealing surfaces				3					
7. Packing ²⁾ Not applicable to RV / HU 2x2 ³⁾ Not applicable to execution Ex ⁶⁾ Only for DN 15 - 150	O - ring EPDM ³⁾				1					
	DRSpack® (PTFE)				3					
	Exp. graphite ^{2) 3)}				5					
	Bellows ⁶⁾				7					
	Bellows with safety PTFE packing ⁶⁾				8					
	Bellows with safety Graphite packing ^{2) 6)}				9					
8. Flow characteristic ⁴⁾ Applicable to UV 2x0 only ⁵⁾ Not applicable to RV 2x4	Linear					L				
	Equal-percentage in straight way					R				
	LDMspline ⁵⁾					S				
	On-off ⁴⁾					U				
	Parabolic ⁵⁾					P				
	Linear - perforated plug ⁵⁾					D				
	Equa -percentage - perforated plug ⁵⁾					Q				
	Parabolic - perforated plug ⁵⁾					Z				
9. Kvs	Column No. acc. to Kvs values table					X				
10. Nominal pressure PN	PN 16						16			
	PN 25 (DN 200 to 400 only)						25			
	PN 40						40			
11. Max. operating temp. °C	O - ring EPDM							140		
	DRSpack® (PTFE), bellows							220		
	DRSpack® (PTFE), bellows							260		
	Exp. graphite; Bellows ²⁾							300		
	Exp. graphite; Bellows ²⁾							400		
	Exp. graphite; Bellows ²⁾							550		
12. Nominal size DN	DN								XXX	
13. Execution	Normal									
	Non - explosive									Ex
	Oxygen									Ox

Ordering example: Two-way control valve DN 65, PN 40, with pneumatic actuator 526 63.2111, body material: spheroidal cast iron, flange with raised face, metal-PTFE seat sealing, PTFE packing, linear characteristic, Kvs = 63 m³/hour is specified as follows: **RV210 PFA 1423 L1 40/220-065.**

Valves RV 2x0 (Ex)

Section of valve with V-ported plug

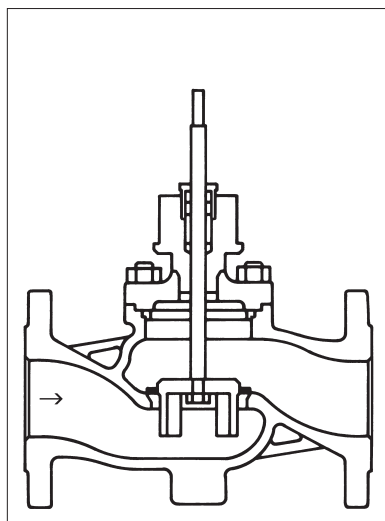

Section of valve with perforated plug

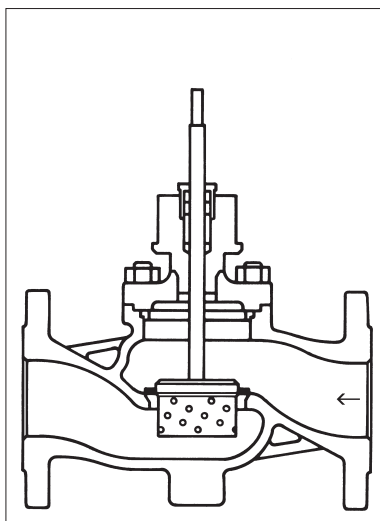

Section of valve with micro-throttling trim

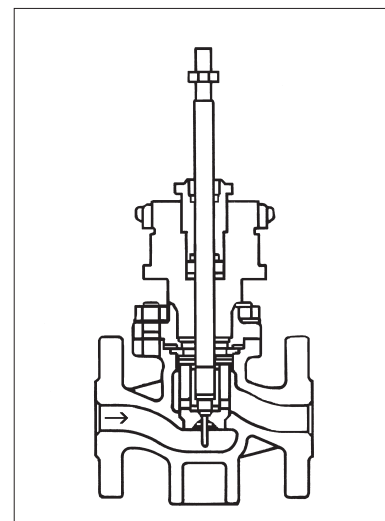

Valves RV 2x2 (Ex)

Section of pressure-balanced valve with V-ported plug

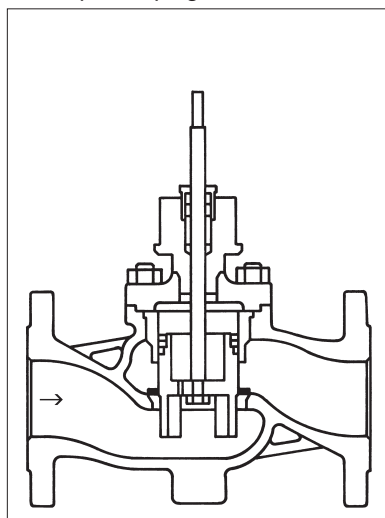

Section of pressure-balanced valve with perforated plug

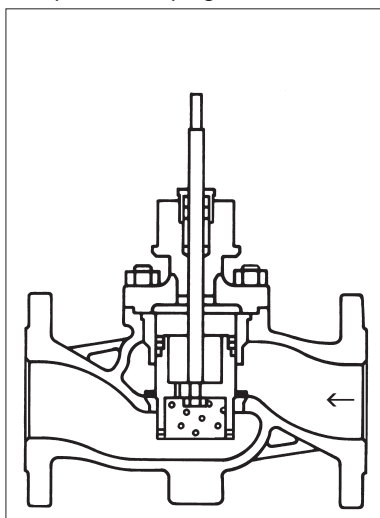

Valves RV 2x4 (Ex)

Section of three-way valve with V-ported plug

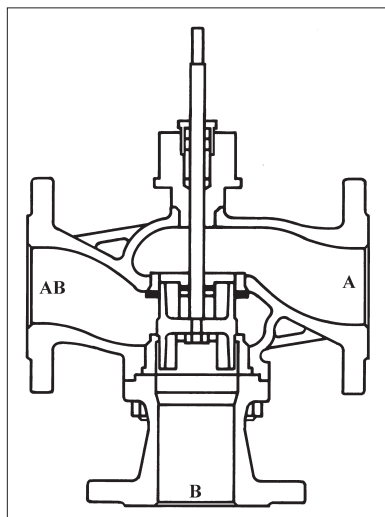



**Pneumatic actuators
Flowserve series 127 to 700**

Technical data

Type	PA 127		PA 252		PB 502		PB 700	
Marking in valve specification No.	PFF		PFA		PFB		PFC	
Feeding pressure	0,6 MPa max							
Function	direct	indirect	direct	indirect	direct	indirect	direct	indirect
Control	Pneumatic signal of 20 - 100 kPa							
	Current signal of 0(4) - 20 mA							
Nominal force	According to table of nominal force values							
Stroke	20 mm				40 mm			
Enclosure	IP 54							
Process medium max. temperature	According to used valve							
Ambient temperature range	-40 to 80°C							
Ambient humidity limit	95 %							
Weight	See table of dimensions							

Accessories

Electropneumatic positioner (analogous) type SRI 990	Device with electric input of 4 (0) to 20 mA and outlet of controlling air into actuator. It is adjusted by switches and potentiometers.
Electropneumatic positioner (intelligent) type SRD 991	Device with electric input of 4 (0) to 20 mA and outlet of controlling air into actuator. It is adjusted by PC and special software.
Pneumatic positioner type SRP 981	Device with pneumatic input of 20 to 100 kPa to control the pneumatic actuators with pneumatic control signal
Signalisation switches type SGE 985	Adjustable end position switches
Air set type A 3420	Reduces the supply air pressure to a value required
Electropneumatic positioner type SRI 986	Analog positioner with input signal of 4 (0) - 20 mA
Air set type A 3420 (0 to 50°C)	Reduces the supply air pressure to a value required
Air set type FRS923 (-40 to 80°C)	Reduces the supply pressure to a value required
Electropneumatic positioner SIPART PS2	Digital with input signal of 4(0) – 20 mA
Solenoid valve, standard type SC G327A001	Direct operated electromagnetic valve, execution 3/2, function U (universal), G 1/4"
Solenoid valve inexplusive, EEx em type EM G327A001	Direct operated electromagnetic valve, execution 3/2, function U (universal), G 1/4", secured execution 3/2, with the increased safety/epoxy encapsulation operator
Solenoid valve inexplusive, EEx d type NF G327A001	Direct operated electromagnetic valve, execution 3/2, function U (universal), G 1/4", flameproof enclosure
Air lock valve, type EIL 200	Retaining device for closing of air pipeline on a pressure drop

Operating conditions

Pneumatic actuators Flowserve can operate with extremely high ambient temperatures with unique resistance to shock loads. They excel with resistance to vibrations and reached 10⁶ of cycles in operation. It is possible to deliver the actuator with both fail to open and fail to close function, possibly with a position blocking (air lock) upon feeding pressure air supply failure. Various accessories can be delivered together with the actuator.

Direct and indirect functions

Direct function ensures that actuator's stem retracts upon control air supply failure (valve opens).
Indirect function ensures that actuator's stem extends upon control air supply failure (valve closes).

Dimensions and weights of Flowserve actuators series 127 to 700

Type	Actuator								Hand wheel				Weight [kg]	
	A	B	C	D	G	H	J	T	D _L	D _S	E	F	Actuator	Actuator w. hw
	[mm]	[mm]	[mm]	[mm]	[mm]	[mm]	[mm]	[mm]	[mm]	[mm]	[mm]	[mm]		
PA 127	198	65	232	115	M10x1	16	110	18	200	160	380	305	9	14,5
PA 252	265	65	232	120	M10x1	16	110	18	200	200	390	315	14	20
PB 502	352	82	264	175	M16x1,5	25, 40	123	20	300	250	590	460	29	38
PB 700	405	82	264	277	M16x1,5	40	120	20	---	350	---	611	40	58

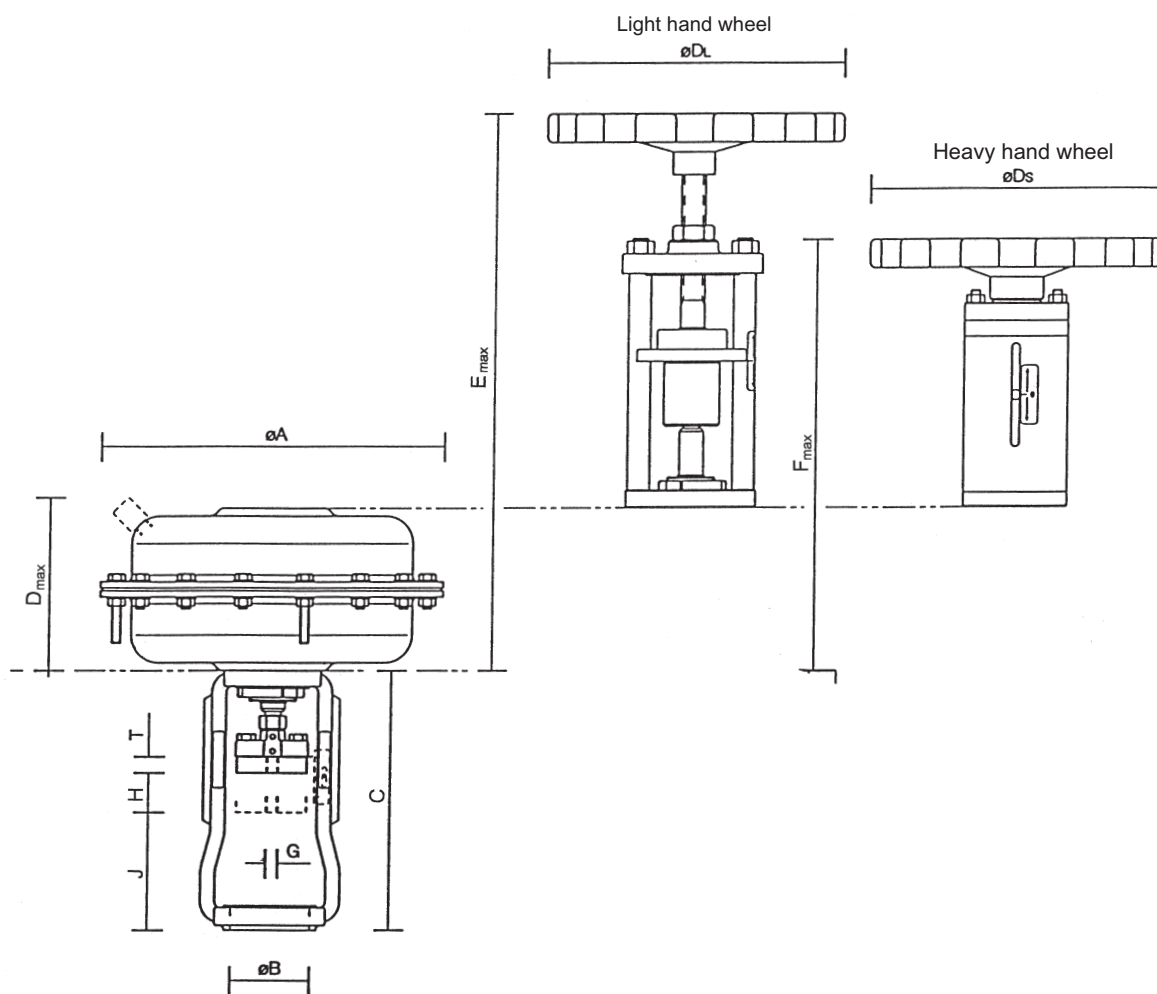

Valve specification No. of Flowserve actuators series 127 to 700

Actuator type	125 cm ²	PX XXX	X	XX	X	X	X
	250 cm ²	PA 127					
	500 cm ²	PA 252					
	700 cm ²	PB 502					
		PB 700					
Colour	white	B					
Spring range [bar]	0,2 - 1,0	AD					
	1,5 - 2,7	VC					
	2,0 - 4,8	FY					
Hand wheel	without wheel					O	
	light wheel					L	
	heavy wheel					H	
Function	direct					A	
	indirect					Z	
Stroke [mm]	20						A
	40						B

PFD, PFE



Pneumatic actuators Flowserve series 1502 a 3002

Technical data

Type	PO 1502		PO 3002	
Marking in valve specification No.	PFD		PFE	
Feeding pressure	0,6 MPa max			
Function	direct	indirect	direct	indirect
Control	Pneumatic signal 20 - 100 kPa Current signal of 0(4) - 20 mA			
Nominal force	According to table of nominal force values			
Stroke	80, 100 mm			
Enclosure	IP 54			
Process medium max. temperature	According to used valve			
Ambient temperature range	-40 to 80°C			
Ambient humidity limit	95 %			
Weight	131 kg		247 kg	

Accessories

Electropneumatic positioner (analogous) type SRI 990	Device with electric input of 4 (0) to 20 mA and outlet of controlling air into actuator. It is adjusted by switches and potentiometers.
Electropneumatic positioner (intelligent) type SRD 991	Device with electric input of 4 (0) to 20 mA and outlet of controlling air into actuator. It is adjusted by PC and special software.
Pneumatic positioner type SRP 981	Device with pneumatic input of 20 to 100 kPa to control the pneumatic actuators with pneumatic control signal
Signalisation switches type SGE 985	Adjustable end position switches
Air set type A 3420	Reduces the supply air pressure to a value required
Electropneumatic positioner type SRI 986	Analog positioner with input signal of 4 (0) - 20 mA
Air set type A 3420 (0 to 50°C)	Reduces the supply air pressure to a value required
Air set type FRS923 (-40 to 80°C)	Reduces the supply air pressure to a value required
Electropneumatic positioner SIPART PS2	Digital with input signal of 4(0) – 20 mA
Solenoid valve, standard type SC G327A001	Direct operated electromagnetic valve, execution 3/2, function U (universal), G 1/4"
Solenoid valve inexplosive, EEx em type EM G327A001	Direct operated electromagnetic valve, execution 3/2, function U (universal), G 1/4", secured execution 3/2, with the increased safety/epoxy encapsulation operator
Solenoid valve inexplosive, EEx d type NF G327A001	Direct operated electromagnetic valve, execution 3/2, function U (universal), G 1/4", flameproof enclosure
Volume Booster-valve, type EIL 100	Flow air volume increaser
Air lock valve, type EIL 200	Retaining device for closing of air pipeline on a pressure drop

Operating conditions

Pneumatic actuators Flowserve can operate with extremely high ambient temperatures with unique resistance to shock loads. They excel with resistance to vibrations and reached 10⁶ of cycles in operation. It is possible to deliver the actuator with both fail to open and fail to close function, possibly with a position blocking (air lock) upon feeding pressure air supply failure. Various accessories can be delivered together with the actuator.

Direct and indirect functions

Direct function ensures that actuator's stem retracts upon control air supply failure (valve opens).
Indirect function ensures that actuator's stem extends upon control air supply failure (valve closes).

Dimensions and weights of Flowserve actuators 1502 a 3002

(execution without hand wheel)

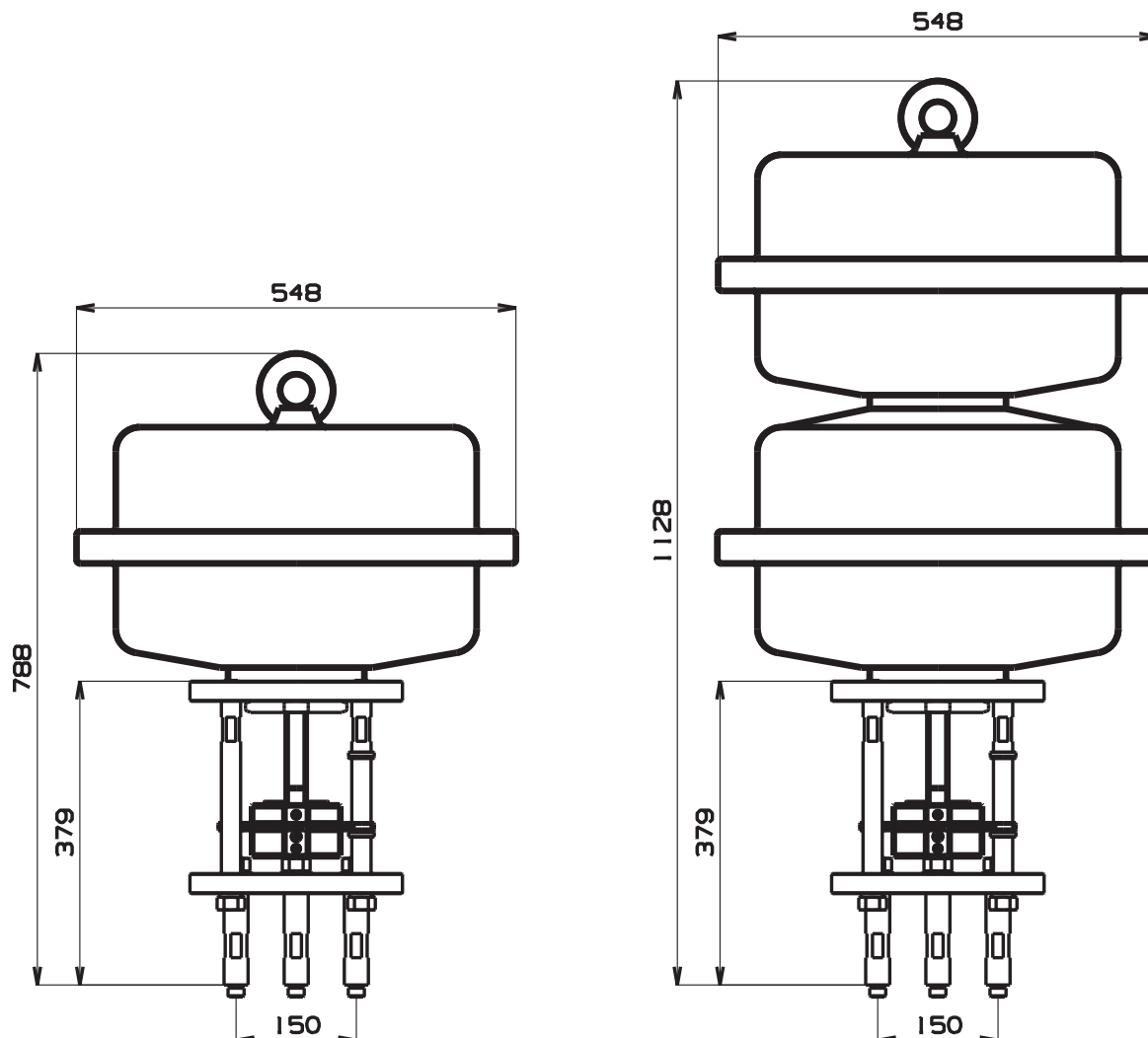

Valve specification No. of Flowserve actuators series 1502 a 3002

		PO XXXX	X	XX	X	X	X	
Actuator type	1500 cm ²	PO 1502						
	3000 cm ²	PO 3002						
Colour		white		B				
Spring range [bar]	PO 1502	H = 80 mm	0,4 - 2,0		GF			
			1,5 - 2,7		VC			
			2,0 - 3,5		FS			
			2,6 - 4,2		AJ			
	PO 3002	H = 100 mm	1,0 - 2,4		DY			
			2,0 - 4,8		FY			
			H = 80 mm	0,4 - 2,0		GF		
				1,3 - 2,1		EP		
H = 100 mm	1,0 - 2,4		DY					
	2,0 - 4,8		FY					
Hand wheel		without wheel				O		
		side light wheel				S		
Function		direct					A	
		indirect					Z	
Stroke [mm]		80					D	
		100					E	

Maximal permissible operating pressures [MPa]

Material	PN	Temperature [°C]										
		120	150	200	250	300	350	400	450	500	525	550
Spheroidal cast iron EN-JS 1025 (EN-GJS-400-18-LT)	16	1,50	1,40	1,40	1,30	1,10	---	---	---	---	---	---
	25, 40	4,00	3,88	3,60	3,48	3,20	---	---	---	---	---	---
Cast steel 1.0619 (GP240GH)	16	1,60	1,50	1,40	1,30	1,10	1,00	0,80	---	---	---	---
	25, 40	4,00	4,00	3,90	3,60	3,20	2,70	1,90	---	---	---	---
CrMo steel 1.7357 (G17CrMo5-5)	---	---	---	---	---	---	---	---	---	---	---	---
	25, 40	4,00	4,00	4,00	4,00	4,00	4,00	3,90	3,10	1,80	---	---
Stained steel 1.4581 (GX5CrNiMoNb19-11-2)	16	1,60	1,50	1,40	1,30	1,30	1,20	1,20	---	---	---	---
	25, 40	4,00	3,80	3,50	3,40	3,30	3,10	3,00	---	---	---	---

Notes:



LDM, spol. s r.o.
Litomyšlská 1378
560 02 Česká Třebová
Czech Republic

tel.: +420 465 502 511
fax: +420 465 533 101
E-mail: sale@ldm.cz
<http://www.ldm.cz>

LDM, spol. s r.o.
Office in Prague
Podolská 50
147 01 Praha 4
Czech Republic

tel.: +420 241 087 360
fax: +420 241 087 192

LDM, spol. s r.o.
Office in Ústí nad Labem
Mezní 4
400 11 Ústí nad Labem
Czech Republic

tel.: +420 475 650 260
fax: +420 475 650 263

LDM servis, spol. s r.o.
Litomyšlská 1378
560 02 Česká Třebová
Czech Republic

tel.: +420 465 502 411-3
fax: +420 465 531 010
E-mail: servis@ldm.cz

LDM, Polska Sp. z o.o.
Modelarska 12
40 142 Katowice
Poland

tel.: +48 32 730 56 33
fax: +48 32 730 52 33
mobile: +48 601 354 999
E-mail: ldmpolska@ldm.cz

LDM Bratislava s.r.o.
Mierová 151
821 05 Bratislava
Slovakia

tel.: +421 2 43415027-8
fax: +421 2 43415029
E-mail: ldm@ldm.sk
<http://www.ldm.sk>

LDM - Bulgaria - OOD
z. k. Mladost 1
bl. 42, floor 12, app. 57
1784 Sofia
Bulgaria

tel.: +359 2 9746311
fax: +359 2 9746311
GSM: +359 888 925 766
E-mail: ldm.bg@ldmvalves.com

OOO "LDM Promarmatura"
Moskovskaya street,
h. 21, Office No. 520
141400 Khimki
Russian Federation

tel.: +7 495 777 22 38
fax: +7 495 777 22 38
E-mail: inforus@ldmvalves.com

TOO "LDM"
Lobody 46/2
Office No. 4
100008 Karaganda
Kazakhstan

tel.: +7 7212 566 936
fax: +7 7212 566 936
mobile: +7 701 738 36 79
E-mail: sale@ldm.kz
<http://www.ldm.kz>

LDM Armaturen GmbH
Wupperweg 21
D-51789 Lindlar
Germany

tel.: +49 2266 440333
fax: +49 2266 440372
mobile: +49 177 2960469
E-mail: ldmmarmaturen@ldmvalves.com
<http://www.ldmvalves.com>

Your partner