



01 - 02.7  
03.23.GB

## TWO-WAY AND THREE-WAY CONTROL VALVES LDM

# RV 113



# RV 113

## Control valves RV 113 R are flanged, 2-way valves with pressure balanced plug (except DN 15 - 25) and high tightness designed for regulation and closing of the medium flow.

Its design enables the valve to be applicable at high differential pressures with low-linear-force actuators. Owing to unique flow characteristic LDMspline®, optimized for regulation of thermodynamic processes, the valves are ideal for applications in heating and air-conditioning. Flow characteristics, Kvs values and leakage rates correspond to international standards.

The valves type RV 113 R have connection to the following actuators: Siemens, Belimo, Ekorex, LDM a PS Automation.

### Application

Control valves RV113 are designed for applications in heating and air-conditioning. Control valves type RV113 are also available in silicone free execution (marking in a specification number SF). The maximum permissible operating pressures are specified below on this page.

### Process media

The valves RV113 are suitable for media such as water, air and other media compatible with material of body and internal parts in range +2 to +150°C.

Sealing surfaces of trim are resistant to common dirt and impurities in medium. However, for abrasive impurities it is recommended to pipe a strainer before the valve to ensure reliable function.

The valve cannot work in cavitation conditions.

### Installation

The valve must be piped with the medium flow according to arrows indicated on the valve body.

The valve can be piped in any position except when the actuator is under the valve body.

### Flow characteristic selection in regard of valve stroke

To make right selection of valve flow characteristic, it is suitable to carry out checking of what stroke values will be reached in different operation states. We recommend to carry out such checking at least for minimal, nominal and maximal flow rates. The principle for flow characteristic selection is to avoid, if possible, 5, 10% of the beginning and end of the valve stroke range.

To calculate valve stroke at different operating conditions with different types of flow characteristics is possible with the advantage of using LDM's calculation programme VALVES. The programme serves for complete design of valve from Kv calculation to specification of a concrete valve with its actuator.

### Packing O-ring EPDM

Well proven type of packing with sealing elements made of high quality EPDM is suitable for operating with temperature of, +2 to +150 C. The packing excels with its reliability and long time tightness. Its properties ensure safe usage in nomaintenance applications. Main preferences of the packing is low frictional forces, sealing capability in both ports (even when there is underpressure in the valve) and service life exceeding 500 000 cycles.

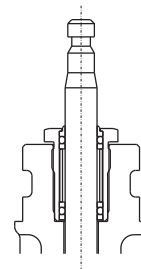



# RV 113 R

Two-way  
control valves

**DN 15 - 40, PN 6**  
**DN 15 - 150, PN 16**  
**DN 15 - 150, PN 25**

## Technical data

<b>Series</b>	<b>RV 113 R</b>	
<b>Type of valve</b>	<b>Two-way control valve</b>	
<b>Nominal size range</b>	DN 15 to 150	
<b>Nominal pressure</b>	DN 15 - 40, PN 6; DN 15 - 150, PN 16	DN 15 - 150, PN 25
<b>Body material</b>	Grey cast iron EN-JL 1040	Spheroidal cast iron EN-JS 1025
<b>Plug material</b>	Stainless steel 1.4027 (1.4028)	
<b>Stem material</b>	Stainless steel 1.4305	
<b>Seat sealing</b>	EPDM	
<b>Packing</b>	EPDM	
<b>Operating temperature range</b>	+2 to +150 °C	
<b>Connection</b>	Flanges type B1 (raised-faced) Acc. to ČSN-EN 1092-2 (1/1999)	
<b>Face to face dimensions</b>	Section 1 acc. to ČSN-EN 558 + A1 (5/2012)	
<b>Type of plug</b>	V-ported with soft seat sealing	
<b>Flow characteristic</b>	LDMspline®	
<b>Kvs values</b>	0,63 to 360 m <sup>3</sup> /h	
<b>Leakage rate</b>	Class IV. - S1 acc. to ČSN-EN 1349 (5/2001) (<0.0005 % Kvs)	
<b>Rangeability r</b>	50:1	

## Maximum permissible operating pressures [MPa] dle ČSN EN 1092-2

Material	PN	Temperature [°C]	
		120	150
Grey cast iron EN-JL 1040 (EN-GJL-250)	6	0,60	0,54
	16	1,60	1,44
Spheroidal cast iron EN-JS 1025 (EN-GJS-400-18-LT)	25	2,50	2,43

## Kvs values and differential pressures

The value  $\Delta p_{\max}$  is maximum differential pressure when reliable closing and opening is guaranteed. Because of the seat and plug service life, it is recommended so that permanent differential pressure would not exceed 0.4 MPa.

For further info on actuating see actuators' catalogue sheets		Actuating (actuator)					see the table on next page								
		Linear force					800 N	1000 N	1500 N	2000 N	2500 N	3200 N	4000 N	4500 N	
		Kvs [m <sup>3</sup> /h]					$\Delta p_{\max}$	$\Delta p_{\max}$	$\Delta p_{\max}$	$\Delta p_{\max}$	$\Delta p_{\max}$	$\Delta p_{\max}$	$\Delta p_{\max}$	$\Delta p_{\max}$	
DN	H	1	2	3	4	5	MPa	MPa	MPa	MPa	MPa	MPa	MPa	MPa	
15	20	4	2.5	1.6	1	0.63	2.28	2.50	2.50	2.50	2.50	---	---	---	
20		6.3	4.0	2.5	---	---	1.43	1.96	2.50	2.50	2.50	---	---	---	
25		10	6.3	4.0	---	---	0.91	1.25	2.11	2.50	2.50	---	---	---	
32		16	10	6.3	---	---	2.50	2.50	2.50	2.50	2.50	---	---	---	
40		25	16	10	---	---	2.50	2.50	2.50	2.50	2.50	---	---	---	
50		40	25	16	---	---	2.50	2.50	2.50	2.50	2.50	2.50	2.50	2.50	
65		63	40	25	---	---	2.50	2.50	2.50	2.50	2.50	2.50	2.50	2.50	
80		100	63	40	---	---	2.50	2.50	2.50	2.50	2.50	2.50	2.50	2.50	
100	40	160	100	63	---	---	---	---	---	2.50	2.50	2.50	2.50	2.50	
125		250	160	100	---	---	---	---	---	2.50	2.50	2.50	2.50	2.50	
150		360	250	160	---	---	---	---	---	2.50	2.50	2.50	2.50	2.50	

Supplied types of actuators			stroke		
<b>Siemens</b>	Electric actuator <b>SAX 31.00 a SAX 31.03</b>	AC 230 V, 3-position control, 800 N	20 mm		
	Electric actuator <b>SAX 81.00 a SAX 81.03</b>	AC/DC 24 V, 3-position control, 800 N			
	Electric actuator <b>SAX 61.03</b>	AC/DC 24 V, control 0...10V, 4...20mA, 0-1000Ω, 800 N			
<b>Belimo</b>	Electric actuator <b>NV230A-RE</b>	AC 230 V, 3-position control, 1000 N	20 mm		
	Electric actuator <b>NV24A-RE</b>	AC/DC 24 V, 3-position control, 1000 N			
	Electric actuator <b>NV24A-MP-RE</b>	AC/DC 24 V, DC (0) 2...10V, 1000 N			
	Electric actuator <b>NVC24A-MP-RE</b>	AC/DC 24 V, DC (0) 2...10V, 1000 N			
	Electric actuator <b>NVK24A-3-RE</b>	AC/DC 24 V, 3-position control, 1000 N			
	Electric actuator <b>NVK24A-MP-RE</b>	AC/DC 24 V, DC (0) 2...10V, 1000 N			
	Electric actuator <b>NVK230A-3-RE</b>	AC 230 V, 3-position control, 1000 N			
	Electric actuator <b>NVKC24A-MP-RE</b>	AC/DC 24 V, DC (0) 2...10V, 1000 N			
	Electric actuator <b>SV24A-MP-RE</b>	AC/DC 24 V, DC (0) 2...10V, 1500 N			
	Electric actuator <b>SV230A-RE</b>	AC 230 V, 3-position control, 1500 N			
	Electric actuator <b>SV24A-RE</b>	AC/DC 24 V, 3-position control, 1500 N			
	Electric actuator <b>SVC24A-MP-RE</b>	AC/DC 24 V, DC (0) 2...10V, 1500 N			
	Electric actuator <b>EV230A-RE</b>	AC 230 V, 3-position control, 2500 N			
	Electric actuator <b>EV24A-RE</b>	AC/DC 24 V, 3-position control, 2500 N			
<b>Ekorex</b>	Electric actuator <b>PTN2-XX.0</b>	AC 230 V, 3-position control, 0...10V, 4...20mA, 2000 - 4000 N	20 - 40 mm		
	Electric actuator <b>PTN2-XX.2</b>	AC 24 V, 3-position control, 0...10V, 4...20mA 2000 - 4000 N			
	<b>LDM</b>	Electric actuator <b>ANT40.11</b>		AC/DC 24 V (230 V with modul), 2500 N 3(2)-position control, 0...10V, 4...20mA	20 - 40 mm
		Electric actuator <b>ANT40.11S</b>		AC/DC 24 V (230 V s modulem), 2000 N 3(2)-position control, 0...10V, 4...20mA fail-safe function - indirect	
Elektrický pohon <b>ANT40.11R</b>		AC/DC 24 V (230 V s modulem), 2000 N 3(2)-position control, 0...10V, 4...20mA fail-safe function - direct			
<b>PS Automation</b>	Electric actuator <b>PSL202 AMS11</b>	AC 230 V, AC/DC 24 V, 2300 N 3-position control, 0(2)-10 V; 0(4)-20 mA	20 - 40 mm		
	Electric actuator <b>PSL204 AMS11</b>	AC 230 V, AC/DC 24 V, 4500 N 3-position control, 0(2)-10 V; 0(4)-20 mA	40 mm		
	Electric actuator <b>PSL204 AMS12</b>	AC 230 V, AC/DC 24 V, 4500 N 3-position control, 0(2)-10 V; 0(4)-20 mA			
	Electric actuator <b>PSF401</b> (mechanical fail-safe function)	AC 230 V, AC/DC 24 V, 1000 N 3-position control, 0(2)-10 V; 0(4)-20 mA	20 mm		
	Electric actuator <b>PSF402</b> (mechanical fail-safe function)	AC 230 V, AC/DC 24 V, 2000 N 3-position control, 0(2)-10 V; 0(4)-20 mA	20 - 40 mm		
	Electric actuator <b>PSF402.1</b> (mechanical fail-safe function)	AC 230 V, AC/DC 24 V, 2000 N 3-position control, 0(2)-10 V; 0(4)-20 mA			
	Electric actuator <b>PSF-M402</b> (hand wheel)	AC 230 V, AC/DC 24 V, 2000 N 3-position control, 0(2)-10 V; 0(4)-20 mA			

### Dimensions and weights for the type RV 113 R

DN	PN 6							PN 16						
	D <sub>1</sub> [mm]	D <sub>2</sub> [mm]	D <sub>3</sub> [mm]	d [mm]	n [mm]	a [mm]	m [kg]	D <sub>1</sub> [mm]	D <sub>2</sub> [mm]	D <sub>3</sub> [mm]	d [mm]	n [mm]	a [mm]	m [kg]
15	80	55	38	11	4	12	2.6	95	65	46	14	4	14	3.5
20	90	65	48	11	4	14	3.5	105	75	56	14	4	16	4.6
25	100	75	58	11	4	14	4.1	115	85	65	14	4	16	5.4
32	120	90	69	14	4	16	6.3	140	100	76	19	4	18	8.5
40	130	100	78	14	4	16	7.9	150	110	84	19	4	18	10.5
50								165	125	99	19	4	20	16.7
65								185	145	118	19	4	20	23.0
80								200	160	132	19	8	22	29.5
100								220	180	156	19	8	24	40.5
125								250	210	184	19	8	26	58.8
150								285	240	211	23	8	26	80.7

DN	PN 25							PN 6, PN 16, PN 25						
	D <sub>1</sub> [mm]	D <sub>2</sub> [mm]	D <sub>3</sub> [mm]	d [mm]	n [mm]	a [mm]	m [kg]	D <sub>4</sub> [mm]	f [mm]	L [mm]	V [mm]	V <sub>1</sub> [mm]	V <sub>2</sub> [mm]	H [mm]
15	95	65	46	14	4	14	3.5	44	2	130	167	65	96	20
20	105	75	56	14	4	16	4.6	44	2	150	167	75	96	20
25	115	85	65	14	4	16	5.4	44	3	160	167	80	96	20
32	140	100	76	19	4	18	8.5	44	3	180	177	90	96	20
40	150	110	84	19	4	19	10.5	44	3	200	187	100	96	20
50	165	125	99	19	4	19	16.7	44	3	230	182	155	96	20
65	185	145	118	19	8	19	23.0	44	3	290	192	185	96	20
80	200	160	132	19	8	19	29.5	44	3	310	212	193	96	20
100	235	190	156	23	8	19	39.8	44	3	350	247	216	116	40
125	270	220	184	28	8	19	56.4	44	3	400	272	239	116	40
150	300	250	211	28	8	20	78.1	44	3	480	297	284	116	40

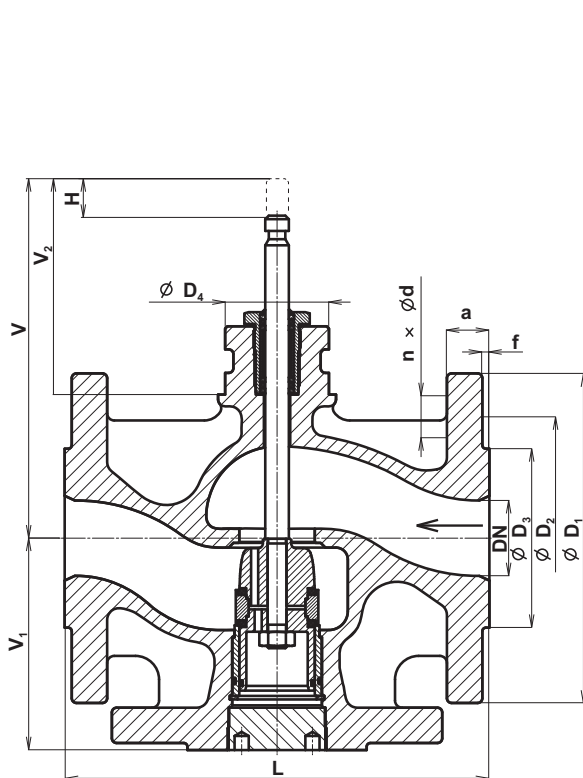

DN 15-40

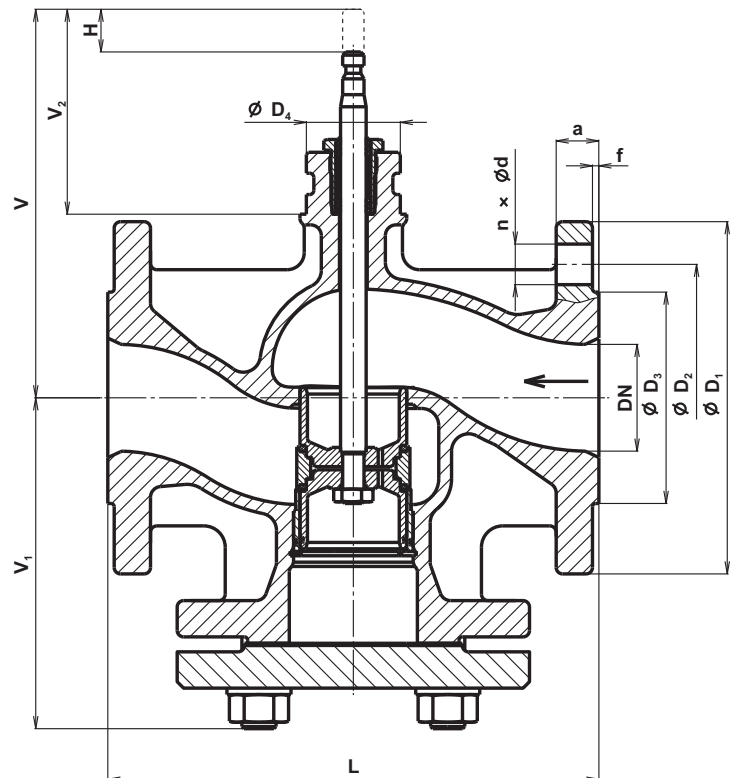

DN 50-150



# RV 113 M

Three-way  
control valves

**DN 15 - 40, PN 6**  
**DN 15 - 150, PN 16**  
**DN 15 - 150, PN 25**

## Technical data

<b>Series</b>	<b>RV 113 M</b>	
<b>Type of valve</b>	<b>Three-way control valve</b>	
<b>Nominal size range</b>	DN 15 to 150	
<b>Nominal pressure</b>	DN 15 - 40, PN 6; DN 15 - 150, PN 16	DN 15 - 150, PN 25
<b>Body material</b>	Grey cast iron EN-JL 1040	Spheroidal cast iron EN-JS 1025
<b>Plug material</b>	Stainless steel 1.4027 (1.4028)	
<b>Stem material</b>	Stainless steel 1.4305	
<b>Seat sealing</b>	EPDM	
<b>Packing</b>	EPDM	
<b>Operating temperature range</b>	+2 to +150 °C	
<b>Connection</b>	Flanges type B1 (raised-faced) Acc. to ČSN-EN 1092-2 (4/2002)	
<b>Face to face dimensions</b>	Section 1 acc. to ČSN-EN 558 (9/2008)	
<b>Type of plug</b>	Flanges type B1 (raised-faced), linear in angle way	
<b>Flow characteristic</b>	LDMspline*	
<b>Kvs values</b>	0,63 to 360 m <sup>3</sup> /h	
<b>Leakage rate</b>	Class IV. - S1 acc. to ČSN-EN 1349 (5/2001) (<0.0005 % Kvs)	
<b>Leakage rate in angle way</b>	not guaranteed (<2% Kvs)	
<b>Rangeability r</b>	50:1	

## Maximum permissible operating pressures [MPa] acc. to ČSN EN 1092-2

Material	PN	Temperatures [°C]	
		120	150
Grey cast iron EN-JL 1040 (EN-GJL-250)	6	0,60	0,54
	16	1,60	1,44
Spheroidal EN-JS 1025 (EN-GJS-400-18-LT)	25	2,50	2,43

## Kvs values and differential pressures

The value  $\Delta p_{max}$  is maximum differential pressure when reliable closing and opening is guaranteed. Because of the seat and plug service life, it is recommended so that permanent differential pressure would not exceed 0.4 MPa (Grey cast iron) respective 0.6 MPa (Spheroidal cast iron).

For further info. on actuating see actuators' catalogue sheets		Actuating (actuator)					see the table on next page									
		Linear force					800 N	1000 N	1500 N	2000 N	2300 N	2500 N	3200 N	4000 N	4500 N	
		Kvs [m <sup>3</sup> /h]					$\Delta p_{max}$	$\Delta p_{max}$	$\Delta p_{max}$	$\Delta p_{max}$	$\Delta p_{max}$	$\Delta p_{max}$	$\Delta p_{max}$	$\Delta p_{max}$	$\Delta p_{max}$	$\Delta p_{max}$
DN	H	1	2	3	4	5	MPa	MPa	MPa	MPa	MPa	MPa	MPa	MPa	MPa	
15	20	4	2.5	1.6	1	0.63	2.28	2.50	2.50	2.50	2.50	2.50	---	---	---	
20		6.3	4.0	2.5	---	---	1.43	1.96	2.50	2.50	2.50	2.50	---	---	---	
25		10	6.3	4.0	---	---	0.91	1.25	2.11	2.50	2.50	2.50	---	---	---	
32		16	10	6.3	---	---	0.56	0.77	1.30	1.83	2.15	2.37	---	---	---	
40		25	16	10	---	---	0.36	0.49	0.84	1.19	1.40	1.54	---	---	---	
50		40	25	16	---	---	0.17	0.25	0.47	0.68	0.81	0.89	1.19	1.53	1.74	
65		63	40	25	---	---	0.10	0.15	0.28	0.41	0.49	0.54	0.72	0.93	1.06	
80		100	63	40	---	---	0.06	0.10	0.19	0.28	0.33	0.36	0.49	0.63	0.71	
100	40	160	100	63	---	---	---	---	---	0.14	0.17	0.19	0.28	0.37	0.43	
125		250	160	100	---	---	---	---	---	0.09	0.11	0.12	0.18	0.24	0.28	
150		360	250	160	---	---	---	---	---	0.06	0.07	0.09	0.12	0.17	0.19	



## Supplied types of actuators

			stroke		
<b>Siemens</b>	Electric actuator <b>SAX 31.00 a SAX 31.03</b>	AC 230 V, 3-position control, 700 N	20 mm		
	Electric actuator <b>SAX 81.00 a SAX 81.03</b>	AC/DC 24 V, 3-position control, 800 N			
	Electric actuator <b>SAX 61.03</b>	AC/DC 24 V, 3-position control, 0...10V, 4...20mA, 0 to 1000 Ohm, 800 N			
<b>Belimo</b>	Electric actuator <b>NV230A-RE</b>	AC 230 V, 3-position control, 1000 N	20 mm		
	Electric actuator <b>NV24A-RE</b>	AC/DC 24 V, 3-position control, 1000 N			
	Electric actuator <b>NV24A-MP-RE</b>	AC/DC 24 V, DC (0) 2...10V, 1000 N			
	Electric actuator <b>NVC24A-MP-RE</b>	AC/DC 24 V, DC (0) 2...10V, 1000 N			
	Electric actuator <b>NVK24A-3-RE</b>	AC/DC 24 V, 3-position control, 1000 N			
	Electric actuator <b>NVK24A-MP-RE</b>	AC/DC 24 V, DC (0) 2...10V, 1000 N			
	Electric actuator <b>NVK230A-3-RE</b>	AC 230 V, 3-position control, 1000 N			
	Electric actuator <b>NVKC24A-MP-RE</b>	AC/DC 24 V, DC (0) 2...10V, 1000 N			
	Electric actuator <b>SV24A-MP-RE</b>	AC/DC 24 V, DC (0) 2...10V, 1500 N			
	Electric actuator <b>SV230A-RE</b>	AC 230 V, 3-position control, 1500 N			
	Electric actuator <b>SV24A-RE</b>	AC/DC 24 V, 3-position control, 1500 N			
	Electric actuator <b>SVC24A-MP-RE</b>	AC/DC 24 V, DC (0) 2...10V, 1500 N			
	Electric actuator <b>EV230A-RE</b>	AC 230 V, 3-position control, 2500 N			
	Electric actuator <b>EV24A-RE</b>	AC/DC 24 V, 3-position control, 2500 N			
<b>Ekorex</b>	Electric actuator <b>PTN2-XX.0</b>	AC 230 V, 3-position control, 0...10V, 4...20mA, 2000 - 4000 N	20 - 40 mm		
	Electric actuator <b>PTN2-XX.2</b>	AC 24 V, 3-position control, 0...10V, 4...20mA, 2000 - 4000 N			
	<b>LDM</b>	Electric actuator <b>ANT40.11</b>		AC/DC 24 V (230 V with modul), 2500 N 3(2)-position control, 0...10V, 4...20mA	20 - 40 mm
		Electric actuator <b>ANT40.11S</b>		AC/DC 24 V (230 V s modulem), 2000 N 3(2)-position control, 0...10V, 4...20mA fail-safe function - indirect	
Electric actuator <b>ANT40.11R</b>		AC/DC 24 V (230 V s modulem), 2000 N 3(2)-position control, 0...10V, 4...20mA fail-safe function - direct			
<b>PS Automation</b>	Electric actuator <b>PSL202 AMS11</b>	AC 230 V, AC/DC 24 V, 2300 N 3-position control, 0(2)-10 V; 0(4)-20 mA	20 - 40 mm		
	Electric actuator <b>PSL204 AMS11</b>	AC 230 V, AC/DC 24 V, 4500 N 3-position control, 0(2)-10 V; 0(4)-20 mA	40 mm		
	Electric actuator <b>PSL204 AMS12</b>	AC 230 V, AC/DC 24 V, 4500 N 3-position control, 0(2)-10 V; 0(4)-20 mA			
	Electric actuator <b>PSF401</b> (fail-safe function)	AC 230 V, AC/DC 24 V, 1000 N 3-position control, 0(2)-10 V; 0(4)-20 mA	20 mm		
	Electric actuator <b>PSF402</b> (fail-safe function)	AC 230 V, AC/DC 24 V, 2000 N 3-position control, 0(2)-10 V; 0(4)-20 mA	20 - 40 mm		
	Electric actuator <b>PSF402.1</b> (fail-safe function)	AC 230 V, AC/DC 24 V, 2000 N 3-position control, 0(2)-10 V; 0(4)-20 mA			
	Electric actuator <b>PSF-M402</b> (hand wheel)	AC 230 V, AC/DC 24 V, 2000 N 3-position control, 0(2)-10 V; 0(4)-20 mA			

### Dimensions and weights for the type RV 113 M

DN	PN 6							PN 16						
	D <sub>1</sub> [mm]	D <sub>2</sub> [mm]	D <sub>3</sub> [mm]	d [mm]	n [mm]	a [mm]	m [kg]	D <sub>1</sub> [mm]	D <sub>2</sub> [mm]	D <sub>3</sub> [mm]	d [mm]	n [mm]	a [mm]	m [kg]
15	80	55	38	11	4	12	2.6	95	65	46	14	4	14	3.5
20	90	65	48	11	4	14	3.5	105	75	56	14	4	16	4.6
25	100	75	58	11	4	14	4.1	115	85	65	14	4	16	5.4
32	120	90	69	14	4	16	6.3	140	100	76	19	4	18	8.5
40	130	100	78	14	4	16	7.9	150	110	84	19	4	18	10.5
50								165	125	99	19	4	20	16.7
65								185	145	118	19	4	20	23.0
80								200	160	132	19	8	22	29.5
100								220	180	156	19	8	24	40.5
125								250	210	184	19	8	26	58.8
150								285	240	211	23	8	26	80.7

DN	PN 25							PN 6, PN 16, PN 25						
	D <sub>1</sub> [mm]	D <sub>2</sub> [mm]	D <sub>3</sub> [mm]	d [mm]	n [mm]	a [mm]	m [kg]	D <sub>4</sub> [mm]	f [mm]	L [mm]	V [mm]	V <sub>1</sub> [mm]	V <sub>2</sub> [mm]	H [mm]
15	95	65	46	14	4	14	3.5	44	2	130	167	65	96	20
20	105	75	56	14	4	16	4.6	44	2	150	167	75	96	20
25	115	85	65	14	4	16	5.4	44	3	160	167	80	96	20
32	140	100	76	19	4	18	8.5	44	3	180	177	90	96	20
40	150	110	84	19	4	19	10.5	44	3	200	187	100	96	20
50	165	125	99	19	4	19	13.0	44	3	230	182	115	96	20
65	185	145	118	19	8	19	18.3	44	3	290	192	145	96	20
80	200	160	132	19	8	19	24.1	44	3	310	212	155	96	20
100	235	190	156	23	8	19	33.1	44	3	350	247	175	116	40
125	270	220	184	28	8	19	46.9	44	3	400	272	200	116	40
150	300	250	211	28	8	20	66.7	44	3	480	297	240	116	40

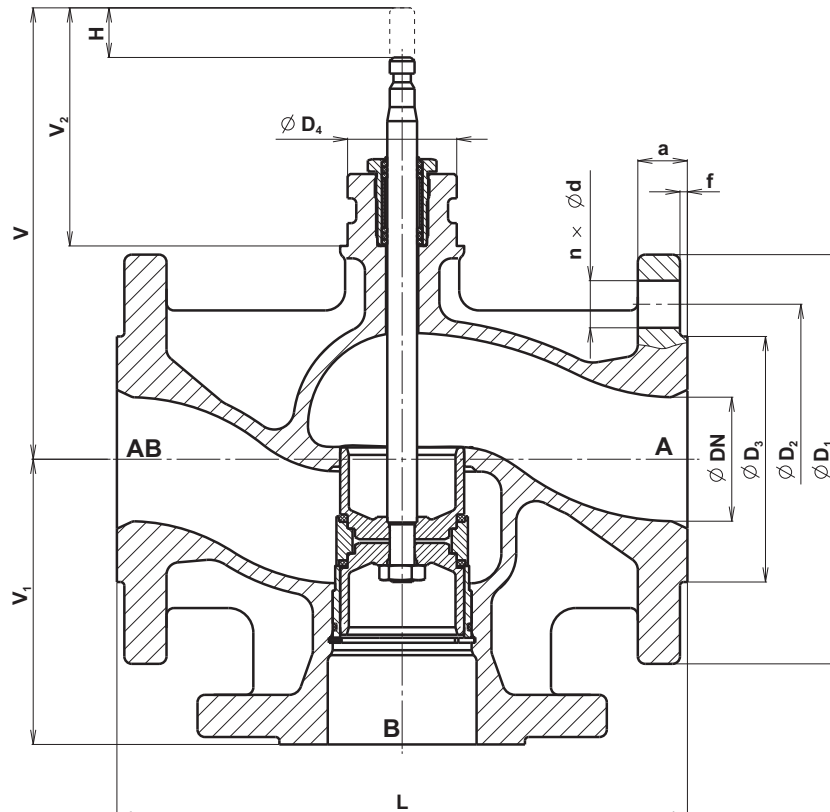



# RV 113 L

Two-way  
control valves

**DN 15 - 40, PN 6**  
**DN 15 - 150, PN 16**  
**DN 15 - 150, PN 25**

## Technical data

Series	RV 113 L	
Type of valve	Two-way control valve	
Nominal size range	DN 15 to 150	
Nominal pressure	DN 15 - 40, PN 6; DN 15 - 150, PN 16	DN 15 - 150, PN 25
Body material	Grey cast iron EN-JL 1040	Spheroidal cast iron EN-JS 1025
Plug material	Stainless steel 1.4027 (1.4028)	
Stem material	Stainless steel 1.4305	
Seat sealing	EPDM	
Packing	EPDM	
Operating temperature range	+2 to +150 °C	
Connection	Flanges type B1 (raised-faced) Acc. to ČSN-EN 1092-2 (1/1999)	
Face to face dimensions	Section 1 acc. to ČSN-EN 558 + A1 (5/2012)	
Type of plug	V-ported with soft seat sealing	
Flow characteristic	LDMspline®	
Kvs values	0,63 to 360 m <sup>3</sup> /h	
Leakage rate	Class IV. - S1 acc. to ČSN-EN 1349 (5/2001) (<0.0005 % Kvs)	
Rangeability r	50:1	

## Maximum permissible operating pressures [MPa] acc. to ČSN EN 1092-2

Material	PN	Temperature [°C]	
		120	150
Grey cast iron EN-JL 1040 (EN-GJL-250)	6	0,60	0,54
	16	1,60	1,44
Spheroidal cast iron EN-JS 1025 (EN-GJS-400-18-LT)	25	2,50	2,43

## Kvs values and differential pressures

The value  $\Delta p_{\max}$  is maximum differential pressure when reliable closing and opening is guaranteed. Because of the seat and plug service life, it is recommended so that permanent differential pressure would not exceed 0.4 MPa (Grey cast iron) respective 0.6 Mpa (Spheroidal cast iron).

For further info. on actuating see actuators' catalogue sheets		Actuating (actuator)					see the table below	
		Linear force					1000 N	2800 N
		Kvs [m <sup>3</sup> /h]					$\Delta p_{\max}$	$\Delta p_{\max}$
DN	H	1	2	3	4	5		
15	20	4	2.5	1.6	1	0.63	2.50	---
20		6.3	4.0	2.5	---	---	1.96	---
25		10	6.3	4.0	---	---	1.25	2.50
32		16	10	6.3	---	---	2.50	2.50
40		25	16	10	---	---	2.50	2.50
50		40	25	16	---	---	2.50	2.50
65		63	40	25	---	---	2.50	2.50
80		100	63	40	---	---	2.50	2.50
100	40	160	100	63	---	---	---	2.50
125		250	160	100	---	---	---	2.50
150		360	250	160	---	---	---	2.50

## Supplied types of actuators

			stroke
Siemens	Electrohydraulic actuator <b>SKD 32.50</b>	AC 230 V, 3-position control, 120 s, 1000 N	20 mm
	Electrohydraulic actuator <b>SKD 82.50</b>	AC 24 V, 3-position control, 120 s, 1000 N	
	Electrohydraulic actuator <b>SKD 32.51</b>	AC 230 V, 3-position control, 120 s, fail-safe fct., 1000 N	
	Electrohydraulic actuator <b>SKD 32.21</b>	AC 230 V, 3-position control, 30 s, fail-safe funct., 1000 N	
	Electrohydraulic actuator <b>SKD 82.51</b>	AC 24 V, 3-position control, fail-safe function, 1000 N	
	Electrohydraulic actuator <b>SKD 60</b>	AC 24 V, control 0...10 V, 4...20 mA, 0-1000Ω, 1000 N	
	Electrohydraulic actuator <b>SKD 62</b>	AC 24 V, control 0...10 V, 4...20 mA, 0-1000Ω, fail-safe fct., 1000 N	
	Electrohydraulic actuator <b>SKD 62UA</b>	AC 24 V, control 0...10 V, 4...20 mA, 0-1000Ω, fail-safe fct., 1000 N	
Siemens	Electrohydraulic actuator <b>SKB 32.50</b>	AC 230 V, 3-position control, 120 s, 2800 N	20 mm
	Electrohydraulic actuator <b>SKB 82.50</b>	AC 24 V, 3-position control, 120 s, 2800 N	
	Electrohydraulic actuator <b>SKB 32.51</b>	AC 230 V, 3-position control, 120 s, fail-safe fct., 2800 N	
	Electrohydraulic actuator <b>SKB 82.51</b>	AC 24 V, 3-position control, 120 s, fail-safe fct., 2800 N	
	Electrohydraulic actuator <b>SKB 60</b>	AC 24 V, control 0...10 V, 4...20 mA, 0-1000Ω, 2800 N	
	Electrohydraulic actuator <b>SKB 62</b>	AC 24 V, control 0...10 V, 4...20 mA, fail-safe fct., 0-1000Ω, 2800 N	
	Electrohydraulic actuator <b>SKB 62UA</b>	AC 24 V, control 0...10 V, 4...20 mA, fail-safe fct., 0-1000Ω, 2800 N	
Siemens	Electrohydraulic actuator <b>SKC 32.50</b>	AC 230 V, 3-position control, 120 s	40 mm
	Electrohydraulic actuator <b>SKC 82.50</b>	AC 24 V, 3-position control, 120 s	
	Electrohydraulic actuator <b>SKC 32.51</b>	AC 230 V, 3-position control, 120 s, fail-safe function	
	Electrohydraulic actuator <b>SKC 82.51</b>	AC 24 V, 3-position control, 120 s, fail-safe function	
	Electrohydraulic actuator <b>SKC 60</b>	AC 24 V, control 0...10 V, 4...20 mA, 0-1000Ω, 2800 N	
	Electrohydraulic actuator <b>SKC 62</b>	AC 24 V, control 0...10 V, 4...20 mA, fail-safe function, 0-1000Ω, 2800 N	
	Electrohydraulic actuator <b>SKC 62UA</b>	AC 24 V, control 0...10 V, 4...20 mA, fail-safe function, 0-1000Ω, 2800 N	

### Dimensions and weights for the type RV 113 L

DN	PN 6							PN 16						
	D <sub>1</sub> [mm]	D <sub>2</sub> [mm]	D <sub>3</sub> [mm]	d [mm]	n [mm]	a [mm]	m [kg]	D <sub>1</sub> [mm]	D <sub>2</sub> [mm]	D <sub>3</sub> [mm]	d [mm]	n [mm]	a [mm]	m [kg]
15	80	55	38	11	4	12	2.6	95	65	46	14	4	14	3.5
20	90	65	48	11	4	14	3.5	105	75	56	14	4	16	4.6
25	100	75	58	11	4	14	4.1	115	85	65	14	4	16	5.4
32	120	90	69	14	4	16	6.3	140	100	76	19	4	18	8.5
40	130	100	78	14	4	16	7.9	150	110	84	19	4	18	10.5
50								165	125	99	19	4	20	16.7
65								185	145	118	19	4	20	23.0
80								200	160	132	19	8	22	29.5
100								220	180	156	19	8	24	40.5
125								250	210	184	19	8	26	58.8
150								285	240	211	23	8	26	80.7

DN	PN 25							PN 6, PN 16, PN 25						
	D <sub>1</sub> [mm]	D <sub>2</sub> [mm]	D <sub>3</sub> [mm]	d [mm]	n [mm]	a [mm]	m [kg]	D <sub>4</sub> [mm]	f [mm]	L [mm]	V [mm]	V <sub>1</sub> [mm]	V <sub>2</sub> [mm]	H [mm]
15	95	65	46	14	4	14	3.5	44	2	130	167	65	96	20
20	105	75	56	14	4	16	4.6	44	2	150	167	75	96	20
25	115	85	65	14	4	16	5.4	44	3	160	167	80	96	20
32	140	100	76	19	4	18	8.5	44	3	180	177	90	96	20
40	150	110	84	19	4	19	10.5	44	3	200	187	100	96	20
50	165	125	99	19	4	19	16.7	44	3	230	182	155	96	20
65	185	145	118	19	8	19	23.0	44	3	290	192	185	96	20
80	200	160	132	19	8	19	29.5	44	3	310	212	193	96	20
100	235	190	156	23	8	19	39.8	44	3	350	247	216	116	40
125	270	220	184	28	8	19	56.4	44	3	400	272	239	116	40
150	300	250	211	28	8	20	78.1	44	3	480	297	284	116	40

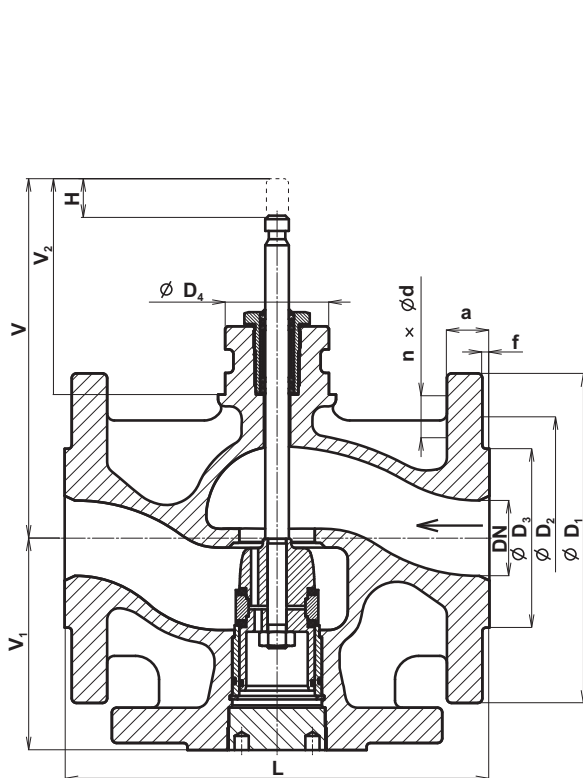

DN 15-40

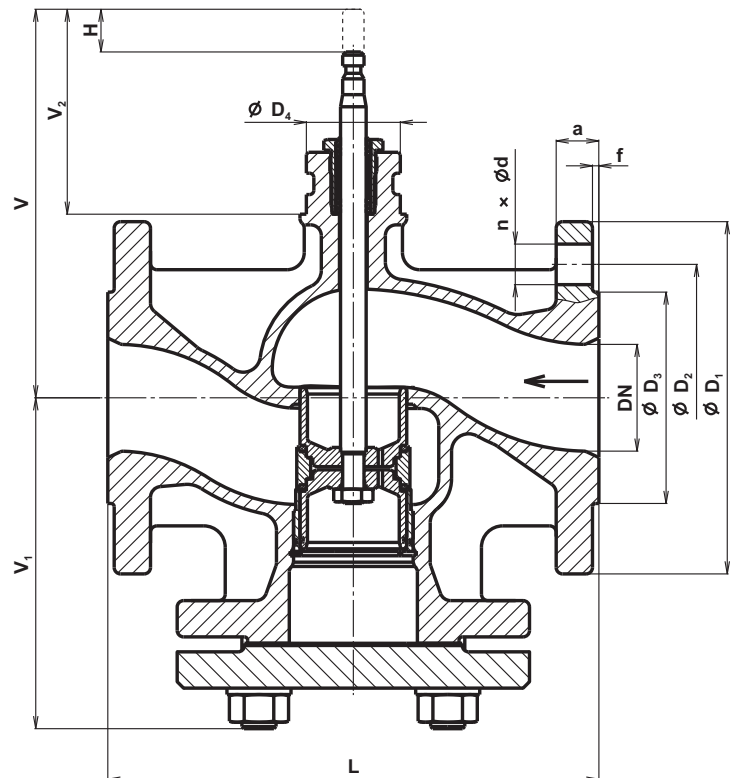

DN 50-150



# RV 113 S

Three-way  
control valves

**DN 15 - 40, PN 6**  
**DN 15 - 150, PN 16**  
**DN 15 - 150, PN 25**

## Technical data

Series	RV 113 S	
Type of valve	Three-way control valve	
Nominal size range	DN 15 to 150	
Nominal pressure	DN 15 - 40, PN 6; DN 15 - 150, PN 16	DN 15 - 150, PN 25
Body material	Grey cast iron EN-JL 1040	Spheroidal cast iron EN-JS 1025
Plug material	Stainless steel 1.4027 (1.4028)	
Stem material	Stainless steel 1.4305	
Seat sealing	EPDM	
Packing	EPDM	
Operating temperature range	+2 to +150 °C	
Connection	Flange type B1 (raised-faced) Acc. to ČSN-EN 1092-2 (4/2002)	
Face to face dimensions	Section 1 acc. to ČSN-EN 558 + A1 (5/2012)	
Type of plug	V-ported with soft seat sealing	
Flow characteristic	LDMspline® in straight way, linear in angle way	
Kvs values	0,63 to 360 m <sup>3</sup> /h	
Leakage rate in direct way	Class IV. - S1 acc. to ČSN-EN 1349 (5/2001) (<0.0005 % Kvs)	
Leakage rate in angle way	Not guaranteed (<2% Kvs)	
Rangeability r	50:1	

## Maximum permissible operating pressures [MPa] dle ČSN EN 1092-2

Material	PN	Temperature [°C]	
		120	150
Grey cast iron EN-JL 1040 (EN-GJL-250)	6	0,60	0,54
	16	1,60	1,44
Spheroidal cast iron EN-JS 1025 (EN-GJS-400-18-LT)	25	2,50	2,43

## Kvs values and differential pressures

The value  $\Delta p_{\max}$  is maximum differential pressure when reliable closing and opening is guaranteed. Because of the seat and plug service life, it is recommended so that permanent differential pressure would not exceed 0.4 MPa (Grey cast iron) respective 0.6 Mpa (Spheroidal cast iron).

For further info. on actuating see actuators' catalogue sheets		Actuating (actuator)					see the table below	
		Linear force					1000 N	2800 N
		Kvs [m <sup>3</sup> /h]					$\Delta p_{\max}$	$\Delta p_{\max}$
DN	H	1	2	3	4	5	MPa	MPa
15	20	4	2.5	1.6	1	0.63	2.50	---
20		6.3	4.0	2.5	---	---	1.96	---
25		10	6.3	4.0	---	---	1.25	2.50
32		16	10	6.3	---	---	0.77	2.50
40		25	16	10	---	---	0.49	1.74
50		40	25	16	---	---	0.25	1.02
65		63	40	25	---	---	0.15	0.62
80		100	63	40	---	---	0.10	0.42
100	40	160	100	63	---	---	---	0.23
125		250	160	100	---	---	---	0.15
150		360	250	160	---	---	---	0.10

## Supplied types of actuators

			stroke
Siemens	Electrohydraulic actuator <b>SKD 32.50</b>	AC 230 V, 3-position control, 120 s, 1000 N	20 mm
	Electrohydraulic actuator <b>SKD 82.50</b>	AC 24 V, 3-position control, 120 s, 1000 N	
	Electrohydraulic actuator <b>SKD 32.51</b>	AC 230 V, 3-position control, 120 s, fail-safe fct., 1000 N	
	Electrohydraulic actuator <b>SKD 32.21</b>	AC 230 V, 3-position control, 30 s, fail-safe funct., 1000 N	
	Electrohydraulic actuator <b>SKD 82.51</b>	AC 24 V, 3-position control, fail-safe function, 1000 N	
	Electrohydraulic actuator <b>SKD 60</b>	AC 24 V, control 0...10 V, 4...20 mA, 0-1000Ω, 1000 N	
	Electrohydraulic actuator <b>SKD 62</b>	AC 24 V, control 0...10 V, 4...20 mA, 0-1000Ω, fail-safe fct., 1000 N	
	Electrohydraulic actuator <b>SKD 62UA</b>	AC 24 V, control 0...10 V, 4...20 mA, 0-1000Ω, fail-safe fct., 1000 N	
Siemens	Electrohydraulic actuator <b>SKB 32.50</b>	AC 230 V, 3-position control, 120 s, 2800 N	20 mm
	Electrohydraulic actuator <b>SKB 82.50</b>	AC 24 V, 3-position control, 120 s, 2800 N	
	Electrohydraulic actuator <b>SKB 32.51</b>	AC 230 V, 3-position control, 120 s, fail-safe fct., 2800 N	
	Electrohydraulic actuator <b>SKB 82.51</b>	AC 24 V, 3-position control, 120 s, fail-safe fct., 2800 N	
	Electrohydraulic actuator <b>SKB 60</b>	AC 24 V, control 0...10 V, 4...20 mA, 0-1000Ω, 2800 N	
	Electrohydraulic actuator <b>SKB 62</b>	AC 24 V, control 0...10 V, 4...20 mA, fail-safe fct., 0-1000Ω, 2800 N	
	Electrohydraulic actuator <b>SKB 62UA</b>	AC 24 V, control 0...10 V, 4...20 mA, fail-safe fct., 0-1000Ω, 2800 N	
Siemens	Electrohydraulic actuator <b>SKC 32.50</b>	AC 230 V, 3-position control, 120 s	40 mm
	Electrohydraulic actuator <b>SKC 82.50</b>	AC 24 V, 3-position control, 120 s	
	Electrohydraulic actuator <b>SKC 32.51</b>	AC 230 V, 3-position control, 120 s, fail-safe function	
	Electrohydraulic actuator <b>SKC 82.51</b>	AC 24 V, 3-position control, 120 s, fail-safe function	
	Electrohydraulic actuator <b>SKC 60</b>	AC 24 V, control 0...10 V, 4...20 mA, 0-1000Ω, 2800 N	
	Electrohydraulic actuator <b>SKC 62</b>	AC 24 V, control 0...10 V, 4...20 mA, fail-safe function, 0-1000Ω, 2800 N	
	Electrohydraulic actuator <b>SKC 62UA</b>	AC 24 V, control 0...10 V, 4...20 mA, fail-safe function, 0-1000Ω, 2800 N	

### Dimensions and weights for the type RV 113 S

DN	PN 6							PN 16						
	D <sub>1</sub> [mm]	D <sub>2</sub> [mm]	D <sub>3</sub> [mm]	d [mm]	n [mm]	a [mm]	m [kg]	D <sub>1</sub> [mm]	D <sub>2</sub> [mm]	D <sub>3</sub> [mm]	d [mm]	n [mm]	a [mm]	m [kg]
15	80	55	38	11	4	12	2.6	95	65	46	14	4	14	3.5
20	90	65	48	11	4	14	3.5	105	75	56	14	4	16	4.6
25	100	75	58	11	4	14	4.1	115	85	65	14	4	16	5.4
32	120	90	69	14	4	16	6.3	140	100	76	19	4	18	8.5
40	130	100	78	14	4	16	7.9	150	110	84	19	4	18	10.5
50								165	125	99	19	4	20	16.7
65								185	145	118	19	4	20	23.0
80								200	160	132	19	8	22	29.5
100								220	180	156	19	8	24	40.5
125								250	210	184	19	8	26	58.8
150								285	240	211	23	8	26	80.7

DN	PN 25							PN 6, PN 16, PN 25						
	D <sub>1</sub> [mm]	D <sub>2</sub> [mm]	D <sub>3</sub> [mm]	d [mm]	n [mm]	a [mm]	m [kg]	D <sub>4</sub> [mm]	f [mm]	L [mm]	V [mm]	V <sub>1</sub> [mm]	V <sub>2</sub> [mm]	H [mm]
15	95	65	46	14	4	14	3.5	44	2	130	167	65	96	20
20	105	75	56	14	4	16	4.6	44	2	150	167	75	96	20
25	115	85	65	14	4	16	5.4	44	3	160	167	80	96	20
32	140	100	76	19	4	18	8.5	44	3	180	177	90	96	20
40	150	110	84	19	4	19	10.5	44	3	200	187	100	96	20
50	165	125	99	19	4	19	13.0	44	3	230	182	115	96	20
65	185	145	118	19	8	19	18.3	44	3	290	192	145	96	20
80	200	160	132	19	8	19	24.1	44	3	310	212	155	96	20
100	235	190	156	23	8	19	33.1	44	3	350	247	175	116	40
125	270	220	184	28	8	19	46.9	44	3	400	272	200	116	40
150	300	250	211	28	8	20	66.7	44	3	480	297	240	116	40

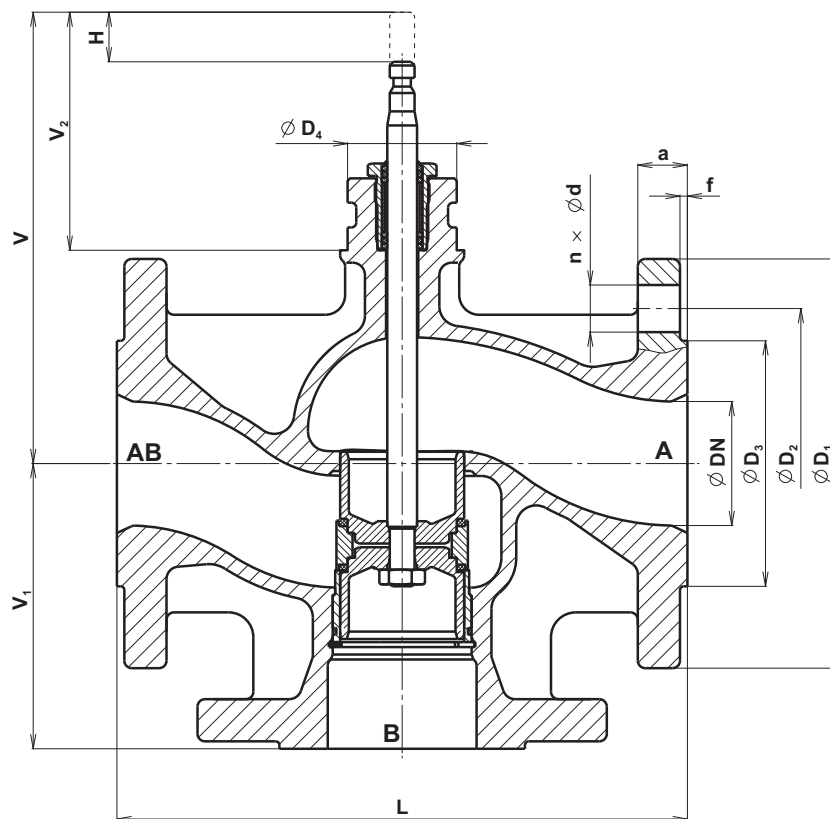



## The valve complete specification No. for ordering RV 113

		XX	XXX	X	XX XX	XX	/	XXX	-	XXX	XX
<b>1. Valve</b>	Control valve	RV									
<b>2. Series</b>	Valves made of grey cast iron		113								
<b>3. Type of valve</b>	Two-way control valve			R							
	Three-way control valve			M							
	Two-way control valve for electrohydraulic actuators			L							
	Three-way control valve for electrohydraulic actuators			S							
<b>4. Execution</b>	Flanged, two-way				4						
	Flanged, three-way mixing (diverting)				6						
<b>5. Body material</b>	Grey cast iron (PN 06, 16)				3						
	Spheroidal cast iron (PN 25)				4						
<b>6. Flow characteristic</b>	LDMspline®/ linear				3						
<b>7. Kvs</b>	Column No. acc. to Kvs value table				X						
<b>8. Nominal pressure PN</b>	PN 6 (grey cast iron only) DN 15 to 40							06			
	PN 16 (grey cast iron only)							16			
	PN 25 (spheroidal cast iron only)							25			
<b>9. Max. temperature °C</b>	150°C								150		
<b>10. Nominal size DN</b>	DN 15 to 150									XXX	
<b>11. Execution</b>	Normal										
	Silicone free										SF

Orderexample: **RV113 R 4331 16/150-065**

The actuator must be specified separately.



Electric actuators

# Siemens

## SAX

Technical data					
Type	SAX 31.00	SAX 31.03	SAX 61.03	SAX 81.00	SAX 81.03
Suitable for valves	RV 113 R, M				
Voltage	230 V AC			24 V AC/DC	
Frequency	50 Hz				
Power consumption	3,5 VA	8 VA	8 VA	3,5 VA	8 VA
Control	3 - position		0 - 10 V, 4 - 20 mA, 0 - 1000 W	3 - position	
Open-close running time	120 s	30 s	30 s	120 s	30 s
Nominal force	800 N				
Travel	20 mm				
Enclosure	IP 54				
Process medium max. temp.	150°C				
Ambient and actuator surface temp. range	-15 to 55°C				
Ambient humidity limit	< 95 % r.v.				
Handle	yes				
Weight (included packing)	1,85 kg				

→ The specification and technical data are informative. Detailed and latest info you can find on [www.siemens.com](http://www.siemens.com)

### Accessories for actuators SAX31..., SAX81... (optional)

Auxiliary switch ASC10.51  
 2x auxiliary switch ASC10.51 (only without ASZ7.5)  
 Potentiometer 135 Ω ASZ7.5/135  
 Potentiometer 200 Ω ASZ7.5/200  
 Potentiometer 1000 Ω ASZ7.5/1000  
 Weather shield ASK39.1  
 Stem heating element (130°C...160°C)

### Accessories for actuators SAX61... (optional)

Auxiliary switch ASC10.51  
 2x auxiliary switch ASC10.51 (only without AZX61.1)  
 Function module AZX61.1  
 Weather shield ASK39.1  
 Stem heating element (130°C...160°C)

### Function module AZX61.1

The functional module allows sequential drive, adaptation of control signal and reversing signal.

## Dimensions of actuator

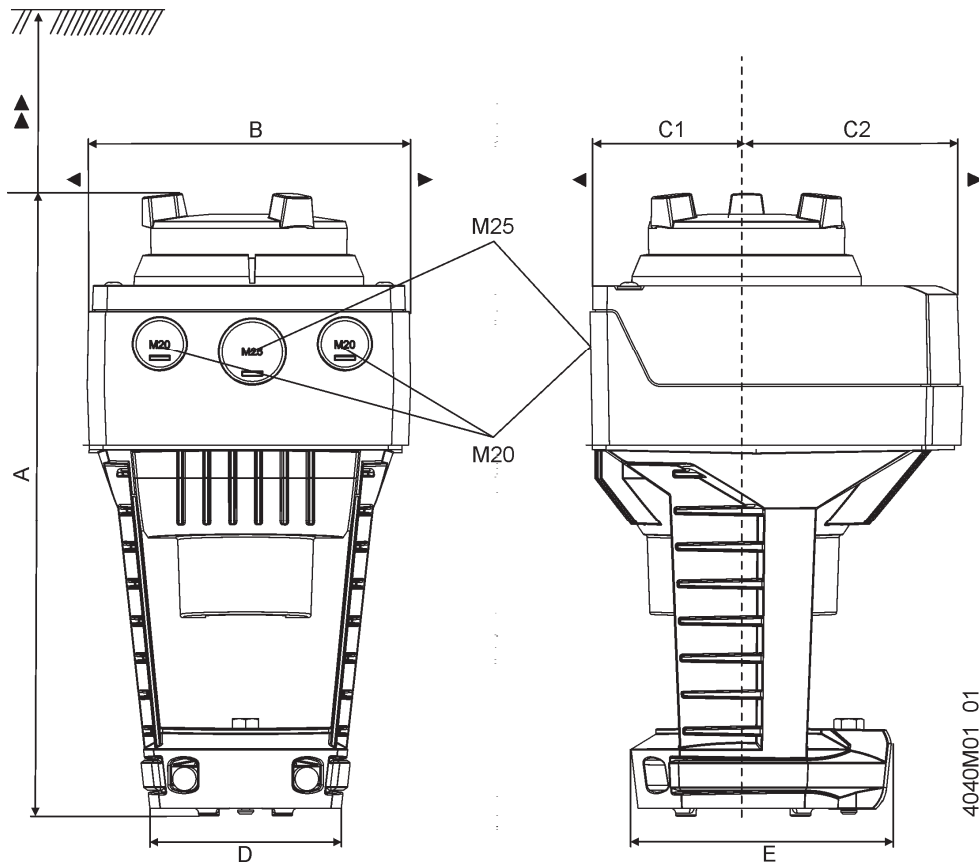

Product type	A	B	C	C1	C2	D	E	>	>>
SAX...	242	124	150	68	82	80	100	100	200
Included cover ASK39.1	+25	154	300	200	100	-	-	-	-

Dimensions in mm

## Connection terminals

### SAX31..

#### AC 230 V, 3-position

- N** — System neutral (SN)
- Y1** — Positioning signal (actuator's stem extends)
- Y2** — Positioning signal (actuator's stem retracts)

### SAX61..

#### AC/DC 24 V, DC 0...10 V / 4...20 mA / 0...1000 Ω

- G0** — System neutral (SN)
- G** — System potential (SP)
- Y** — Positioning signal for DC 0...10 V / 4...20 mA
- M** — Measuring neutral
- U** — Position feedback DC 0...10 V
- Z** — Positioning signal forced control

### SAX81..

#### AC/DC 24 V, 3-position

- G** — System potential (SP)
- Y1** — Positioning signal (actuator's stem extends)
- Y2** — Positioning signal (actuator's stem retracts)

### Auxiliary switch

#### ASC10.51

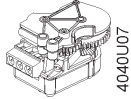

#### Adjustable switching points, AC 24...230 V

- 1** — System potential (SP)
- 2** — Opening
- 3** — Closing

### Potentiometer

#### ASZ7.5/..

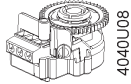

#### Adjustment of zero point, DC 10 V

- 1** — Measuring neutral
  - 2** — 0...x W
  - 3** — x...0 W
- x = 135 W, 200 W; 1000 W

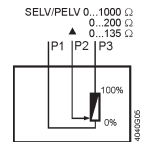
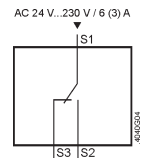

## Connection diagrams

### SAX31..

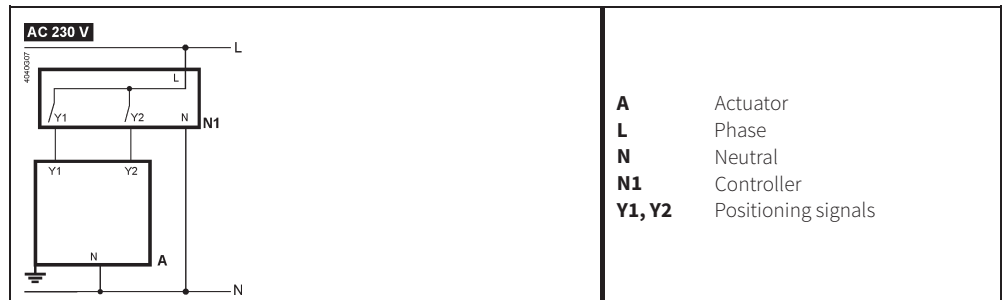

### SAX61..

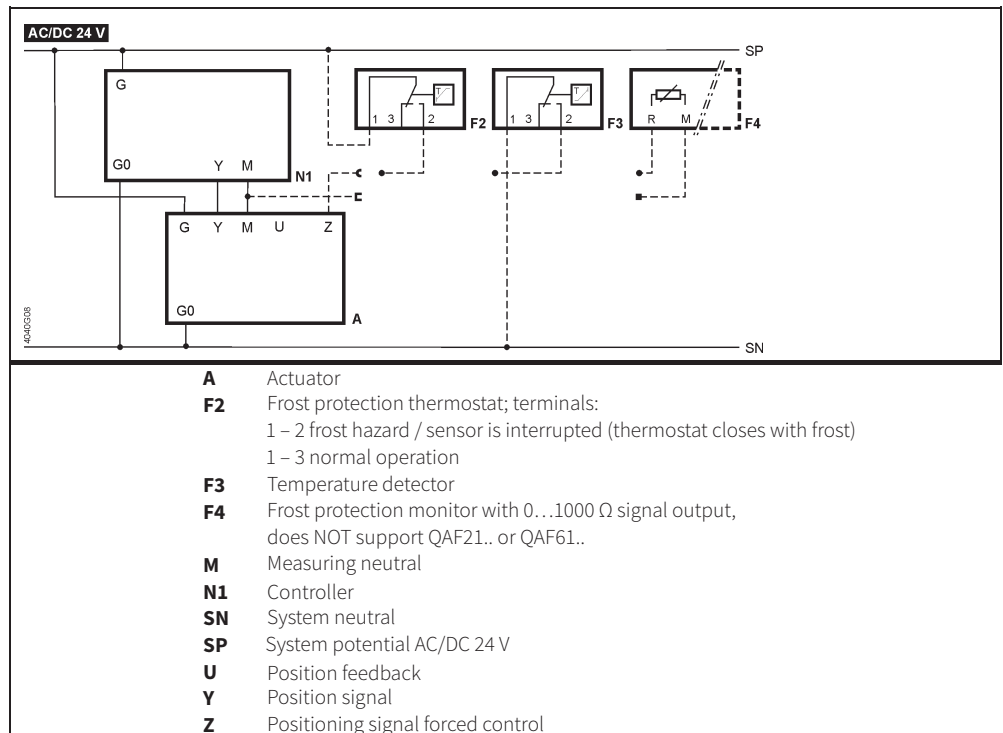

### SAX81..

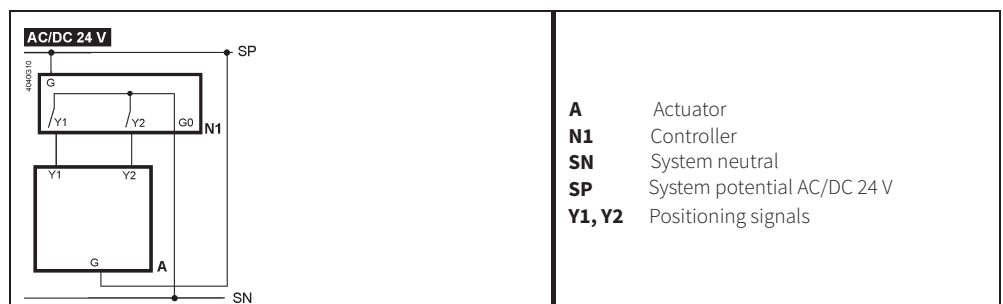



Elektrohydraulic  
actuators

# Siemens

SKD 32..., SKD 82...

Technical data					
Type	SKD 32.50	SKD 82.50	SKD 32.51	SKD 32.21	SKD 82.51
Suitable for valves	RV 113 L, S				
Voltage	230 V AC	24 V AC	230 V AC		24 V AC
Frequency	50...60 Hz				
Power consumption	10 VA		15 VA		
Control	3 - position		3 - position		
Running time	open	120 s	120 s	30 s	120 s
	closed	120 s	120 s	10 s	120 s
Fail-safe action time	---		8 s		
Nominal force	1000 N				
Travel	20 mm				
Enclosure	IP 54				
Process medium max. t.	150 °C				
Ambient and actuator's surface temp. limit	-15 to 50 °C				
Ambient humidity limit	5 - 95 % of relative humidity				
Weight	3,6 kg				

## Accessories (optional)

Pair of auxiliary switches ASC9.3

Potentiometer 1000 Ω ASZ7.3 \*)

Potentiometer 135 Ω ASZ7.31 \*)

Potentiometer 200 Ω ASZ7.32 \*)

\*) only one potentiometer can be used per actuator

## Dimensions of actuator

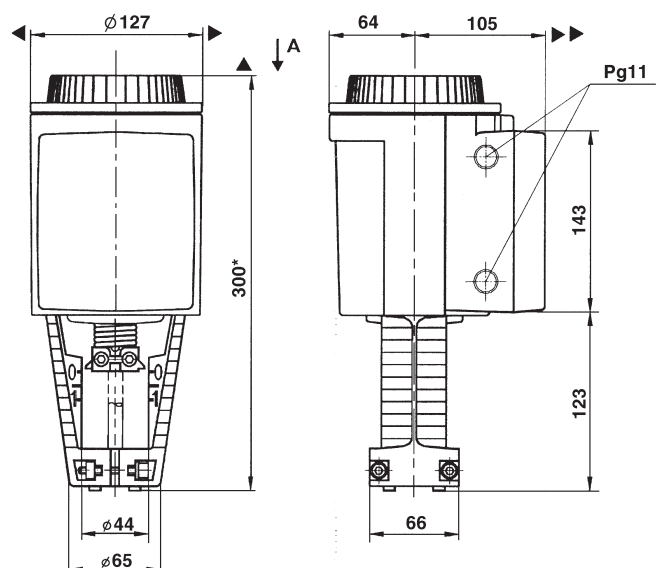

## Wiring diagram of actuator

### SKD32...

AC 230 V

3-position

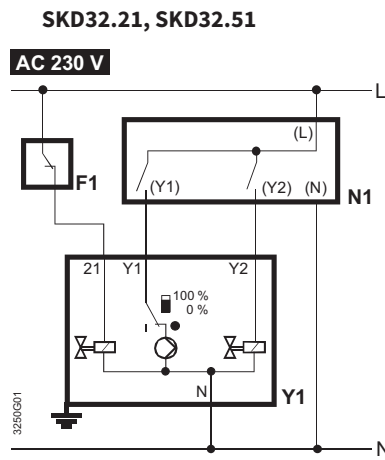

**F1** safety thermostat  
**N1, N2** regulators  
**Y1, Y2** actuators

**L** phase  
**N** zero

### SKD32.50

**AC 230 V**

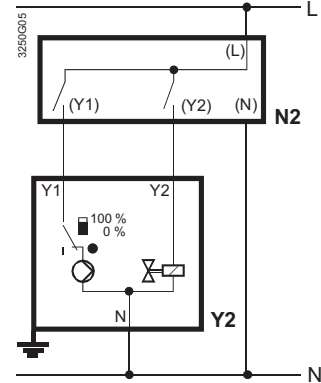

**Y1** control signal «opens»  
**Y2** control signal «closes»  
**21** fail-safe function

### SKD82...

AC 24 V

3-position

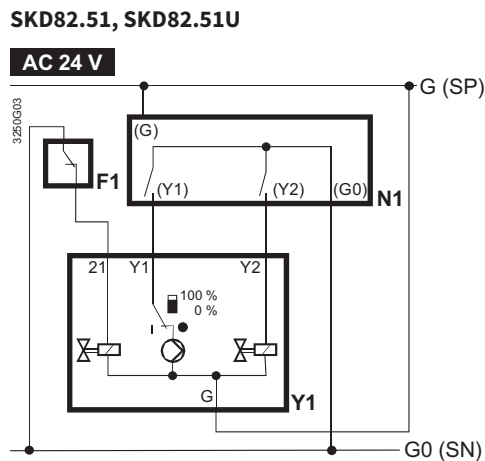

**F1** safety thermostat  
**N1, N2** regulators  
**Y1, Y2** actuators

**SP** system potential AC 24 V  
**SN** system zero

### SKD82.50, SKD82.50U

**AC 24 V**

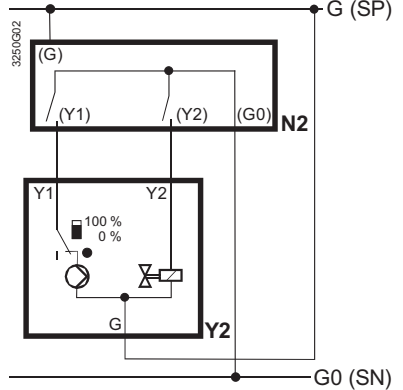

**Y1, Y2** regulator contacts  
**Y1** control signal (opens)  
**Y2** control signal (closes)  
**21** fail-safe function



Elektrohydraulické  
pohony

# Siemens

SKD 60..., SKD 62...

Technical data			
Type	SKD 60	SKD 62	SKD 62UA *)
Suitable for valves		RV 113 L, S	
Voltage		24 V AC	
Frequency		50...60 Hz	
Power consumption		17 VA / 12 VA	
Control		0 - 10 V, 4 - 20 mA, 0 - 1000 Ω	
Running time	open	30 s	
	closed	15 s	
Fail-safe action time	---		15 s
Nominal force		1000 N	
Travel		20 mm	
Enclosure		IP 54	
Process medium max. t.		150°C	
Ambient and actuator's surface temp. limit		-15 to 50 °C	
Ambient humidity limit		5 - 95 % of relative humidity	
Weight	3,6 kg	3,85 kg	3,6 kg

\*) UA ... version with improved electronics

## Accessories

Auxiliary switch 24 V ASC1.6

## Description

Each actuator with continuous control signal is equipped with ACT control technology enabling the following features as standard:

- stroke range calibration
- state indication via LED
- flow characteristic selection (log / lin)
- selection of control signal at Y terminal
- feedback signal at U terminal corresponding to control signal at Y terminal
- forced control at Z terminal

Version with improved electronics (UA) further enables:

- inversion of control signal
- sequence control
- stroke limiting

## Dimensions of actuator

All values in v mm

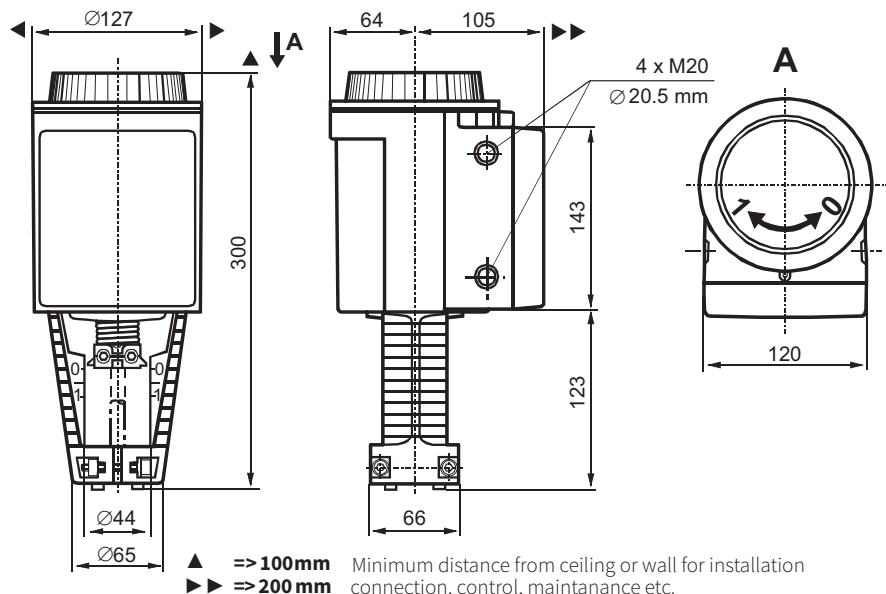



## Connection terminals

SKD6...

<b>G0</b>	Voltage AC 24 V: System neutral (SN)
<b>G</b>	Voltage AC 24 V: System potential (SP)
<b>Y</b>	Control input DC 0...10 (30) V or DC 4...20 mA
<b>M</b>	Measuring neutral (=G0)
<b>U</b>	Output for measuring voltage DC 0...10 V or DC 4...20 mA
<b>Z</b>	Input for forced control

**Auxiliary contact  
ASC1.6**

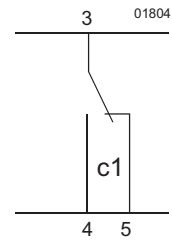

## Wiring diagram

SKD6..

AC 24 V  
DC 0...10 V, 4...20 mA,  
0...1000 Ω

SKD60

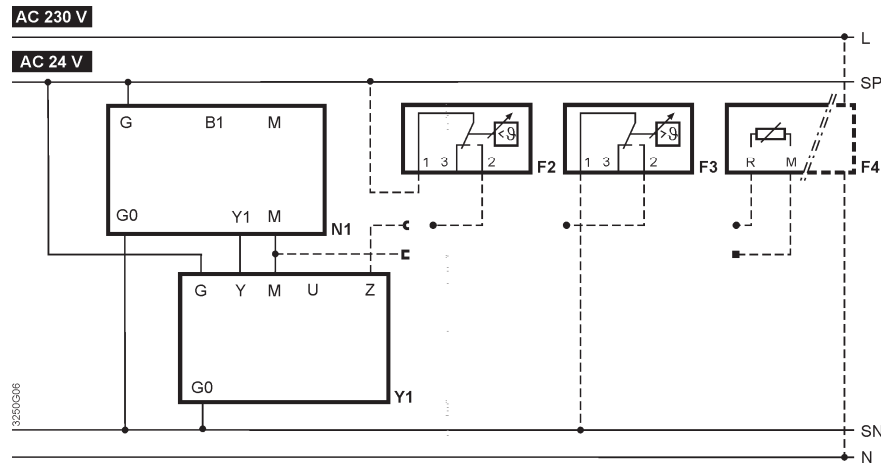

SKD62  
SKD62UA

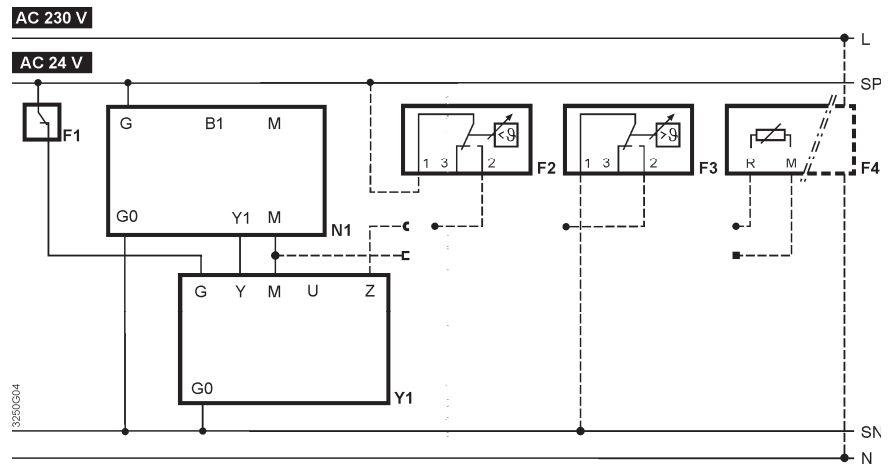

- Y1** actuator
- N1** regulator
- F1** safety thermostat
- F2** anti-freeze thermostat
  - clutches: 1 – 3 the risk of freezing / contact is open (contact switched by frost)
  - 1 – 2 normal operation
- F3** temperature indicator
- F4** anti-freeze monitor with output 0...1000 Ω, for example: QAF21.. or QAF61.. (only for SKD62UA) \*
- G (SP)** system potential AC 24 V
- G0 (SN)** system zero

\* Only for sequential control and appropriate switch settings



Electrohydraulic actuators

**Siemens**

**SKB 32..., SKB 82...  
SKC 32..., SKC 82...**

Technical data								
Type	SKB 32.50	SKB 82.50	SKB 32.51	SKB 82.51	SKC 32.60	SKC 82.60	SKC 32.61	SKC 82.61
Suitable for valves	RV 113 L, S							
Voltage	230 V AC	24 V AC	230 V AC	24 V AC	230 V AC	24 V AC	230 V AC	24 V AC
Frequency	50...60 Hz							
Power consumption	10 VA		15 VA		19 VA		24 VA	
Control	3 - position							
Running time	open		120 s		120 s		120 s	
	closed		120 s		120 s		120 s	
Fail-safe action time	---		10 s		---		18 s	
Nominal force	2800 N							
Travel	20 mm				40 mm			
Enclosure	IP 54							
Process medium max.t.	150 °C							
Ambient and actuator's surface temperature range	-15 to 55 °C							
Ambient humidity range	0 - 95 % of relative humidity							
Weight	8,4 kg		8,9 kg		10 kg		10,5 kg	

### Accessories (optional)

Pair of auxiliary switches ASC9.3

Potentiometer 1000 Ω ASZ7.3 \*)

Potentiometer 135 Ω ASZ7.31 \*)

Potentiometer 200 Ω ASZ7.32 \*)

\*) only one potentiometer can be used per actuator

### Dimensions of actuator

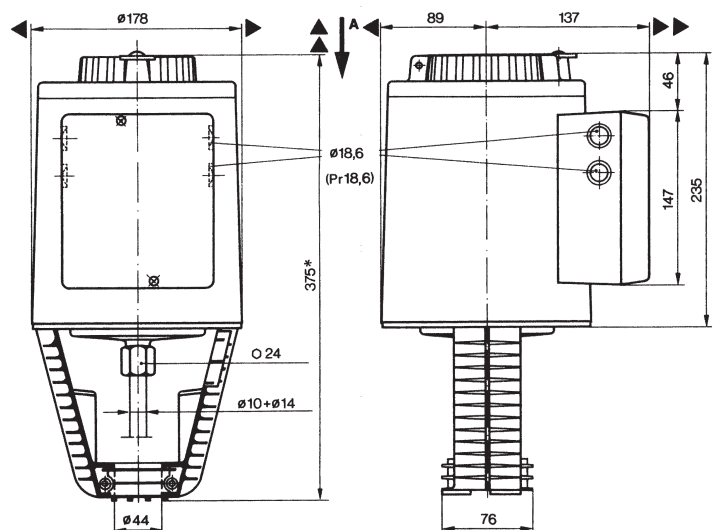

▲ => 100mm Minimum distance from ceiling or wall for installation  
▶ => 200mm connection, control, maintenance etc.

## Wiring diagram

### SKB32...; SKC 32..

AC 230 V  
3-position

#### SKB32.51, SKC 32.51

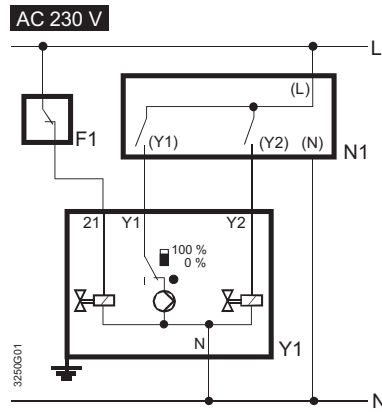

**F1** safety thermostat                      **L** phase  
**N1, N2** regulator                            **N** zero  
**Y1, Y2** actuators

#### SKB32.50, SKC 32.50

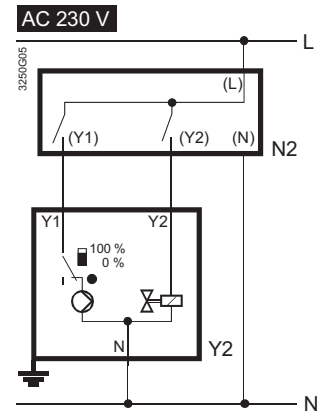

**Y1** control signal «opens»  
**Y2** control signal «closes»  
**Z1** fail-safe function

### SKB82...; SKC82..

AC 24 V  
3-position

#### SKB82.51, SKC82.51

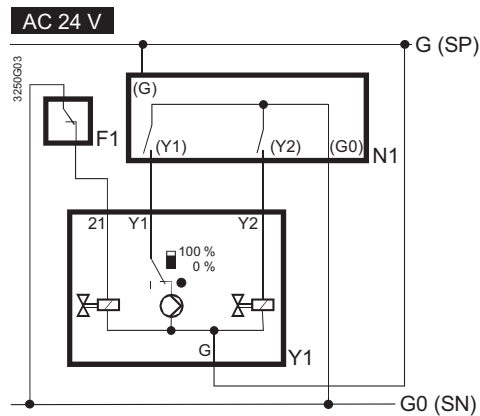

**F1** safety thermostat                      **SP** system potential AC 24 V  
**N1, N2** regulator                            **SN** system zero  
**Y1, Y2** actuators

#### SKB82.50, SKC82.50

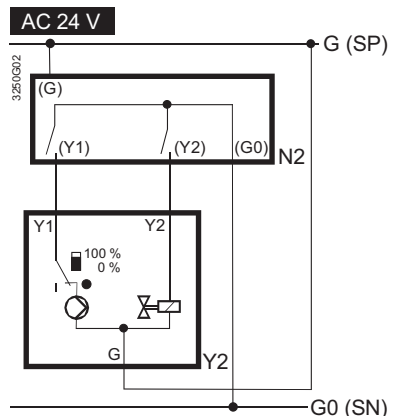

**Y1** control signal «opens»  
**Y2** control signal «closes»  
**Z1** fail-safe function



Electrohydraulic  
actuators

# Siemens

**SKB 60..., SKB 62...**  
**SKC 60..., SKC 62...**

Technical data						
Type	SKB 60	SKB 62	SKB 62UA *)	SKC 60	SKC 62	SKC 62UA *)
Suitable for valves	RV 113 L, S					
Voltage	24 V					
Frequency	50...60 Hz					
Power consumption	13 VA	17 VA		24 VA	28 VA	
Control	0 - 10 V, 4 - 20 mA, 0 - 1000 Ω					
Running time		120 s			120 s	
open						
closed		15 s			20 s	
Fail-safe action time	---	15 s		---	20 s	
Nominal force	2800 N					
Travel	20 mm			40 mm		
Enclosure	IP 54					
Process medium max.t.	150 °C					
Ambient and actuator's surface temperature range	-15 to 55 °C					
Ambient humidity range	0 - 95 % of relative humidity					
Weight	8,6 kg			10 kg		

\*) UA ... version with improved electronics

## Accessories

Auxiliary switch 24 V ASC1.6

## Description

Each actuator with continuous control signal is equipped with ACT control technology enabling the following features as standard:

- stroke range calibration
- state indication via LED
- flow characteristic selection (log/lin)
- selection of control signal at Y terminal
- feedback signal at U terminal corresponding to control signal at Y terminal
- forced control at Z terminal

Version with improved electronics (UA) further enables:

- inversion of control signal
- sequence control
- stroke limiting

## Dimensions of actuator

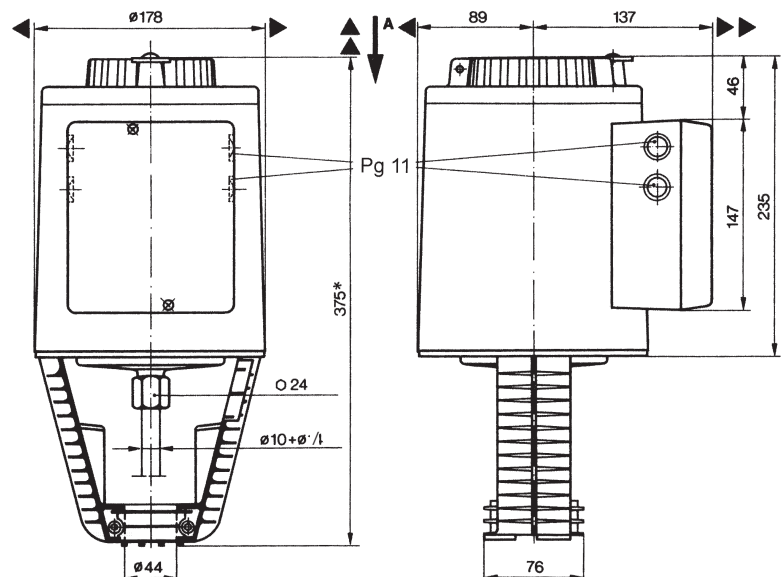

## Connection terminals

<b>G0</b>	Voltage AC 24 V: System neutral (SN)
<b>G</b>	Voltage AC 24 V: System potential (SP)
<b>Y</b>	Control input DC 0...10 (30) V or DC 4...20 mA
<b>M</b>	Measuring neutral (=G0)
<b>U</b>	Output for measuring voltage DC 0...10 V or DC 4...20 mA
<b>Z</b>	Input for forced control

**Auxiliary contact ASC1.6**

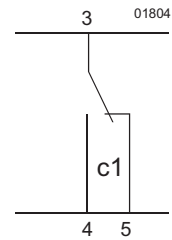

## Wiring diagram

**SKB6.., SKC6..**  
 AC 24 V  
 DC 0...10 V, 4...20 mA,  
 0...1000 Ω

**SKB60  
 SKC60**

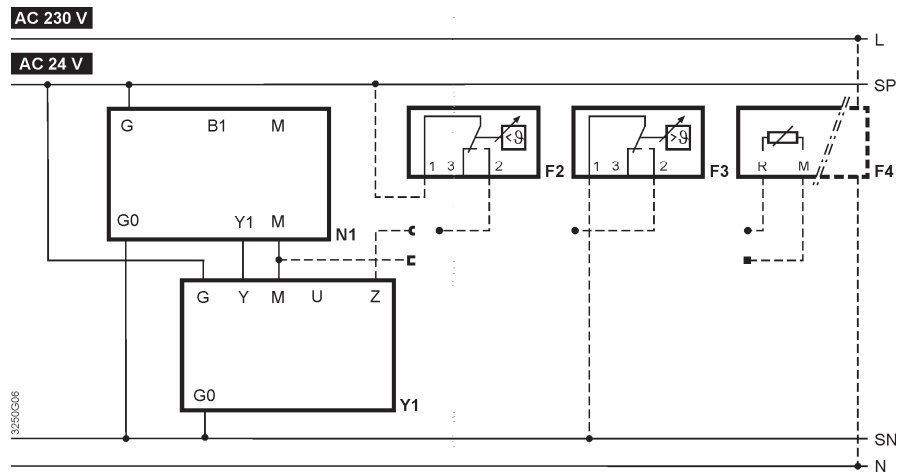

**SKB62  
 SKB62UA  
 SKC62  
 SKC62UA**

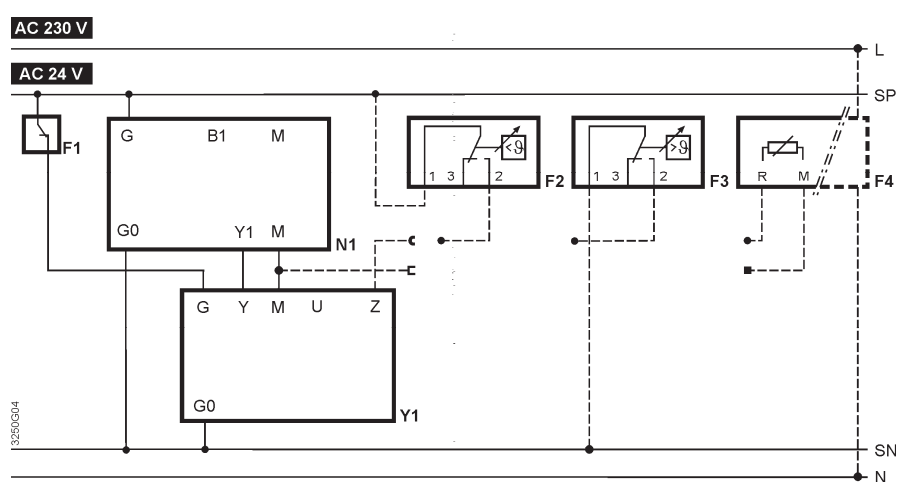

- Y1** actuator
- N1** regulator
- F1** safety thermostat
- F2** anti-freeze thermostat
  - clutches: 1-3 the risk of freezing / contact is open (contact switched by frost)
  - 1-2 normal operation
- F3** temperature indicator
- F4** anti-freeze monitor with output 0...1000 Ω, for example: QAF21.. or QAF61.. (only for SKD62UA) \*
- G (SP)** system potential AC 24 V
- G0 (SN)** system zero

\* Only for sequential control and appropriate switch settings



Electric actuators

**Belimo****NV..., SV..., EV..., RV...**

Technical data						
Type	NV230A-RE	NV24A-RE	NV24A-MP-RE	NVC24A-MP-RE	NVK24A-3-RE	NVK24A-MP-RE
Suitable for valves	<b>RV 113 R, M</b>					
Voltage	AC 230 V	AC/DC 24 V				
Frequency	50 / 60 Hz					
Motor power / Sizing	2 W / 4,5 VA	1,5 W / 3 VA	3,5 W / 5,5 VA	2,5 W / 6 VA		
Control	3 - position		DC (0)2...10V adjustable		3 - position	DC (0)2...10V adjustable
Running time (for 20 mm)	150 s		35 s		150 s	
Fail-safe action time	---				35 s	
Fail-safe function	---				NC, NO, lze nastavit libovolnou pozici	
Nominal force	1000 N					
Travel	20 mm					
Enclosure	IP 54					
Process medium max. temp.	+5 ... 150 °C					
Ambient temperature range	0 to 50 °C					
Ambient humidity limit	5 ... 95 %					
Weight	2,6 kg	2,5 kg	2,6 kg	2,8 kg		

Technical data							
Type	NVK230A-3-RE	NVKC24A-MP-RE	SV24A-MP-RE	SVC230A-RE	SV24A-RE	SVC24A-MP-RE	
Suitable for valves	<b>RV 113 R, M</b>						
Voltage	AC 230 V	AC/DC 24 V		AC 230 V	AC/DC 24 V		
Frequency	50 / 60 Hz						
Motor power / Sizing	2 W / 4,5 VA	2 W / 3,5 VA	4,5 W / 9 VA	2 W / 4 VA	2,5 W / 5 VA	4 W / 6 VA	
Control	3 - position	DC (0)2...10V adjustable		3 - position		DC (0)2...10V adjustable	
Running time (for 20 mm)	150 s	35 s	150 s		35 s		
Fail-safe action time	35 s			---			
Fail-safe function	NC, NO, adjustable position			---			
Nominal force	1000 N			1500 N			
Travel	20 mm						
Enclosure	IP 54						
Process medium max. temp.	+5 ... 150 °C						
Ambient temperature range	0 až 50 °C						
Ambient humidity limit	5 ... 95 %						
Weight	2,9 kg	2,8 kg	2,6 kg				

Technical data					
Type	EV230A-RE	EV24A-RE	EV24A-MP-RE	EVC24A-MF-RE	RV24A-MF-RE
Suitable for valves	RV 113 R, M				
Voltage	AC 230 V		AC/DC 24 V		
Frequency	50 / 60 Hz				
Motor power / Sizing	5,5 W / 9,5 VA	2 W / 4,5 VA	4 W / 6 VA	11 W / 18 VA	6 W / 11 VA
Control	3 - position		DC (0)2...10V adjustable		
Running time (for 20 mm)	150 s		35 s	150 s	
Fail-safe action time	---				
Fail-safe function	---				
Nominal force	2500 N			4500 N	
Travel	40 mm				
Enclosure	IP 54				
Process medium max. temp.	+5 ... 150 °C				
Ambient temperature range	0 to 50 °C				
Ambient humidity limit	5 ... 95 %				
Weight	7,4 kg			7,5 kg	

→ The specification and technical data are informative. Detailed and latest info you can find on [www.belimo.ch](http://www.belimo.ch)

Dimensions of actuator								
Type	Dimensions [mm]							Drawing
	A	B	C	D	E	F	G	
NV230A-RE	193	113	200	190	290	45	---	draw. 1
NV24A-RE	193	113	200	190	290	45	---	
NV24A-MP-RE	215	113	200	190	290	45	---	
NVC24A-MP-RE	215	113	200	190	290	45	---	
NVK24A-3-RE	244	113	217	207	307	45	---	
NVK24A-MP-RE	244	113	217	207	307	45	---	
NVK230A-3-RE	250	113	209	207	307	45	---	draw. 1
NVKC24A-MP-RE	244	113	217	207	307	45	---	
SV24A-MP-RE	215	113	200	190	290	45	---	
SV230A-RE	215	113	200	190	290	45	---	
SV24A-RE	193	113	200	190	290	45	---	
SVC24A-MP-RE	215	113	200	190	290	45	---	draw. 2
EV230A-RE	227	140	342...408	---	315	53	44...110	
EV24A-RE	205	140	342...408	---	315	53	44...110	
EV24A-MP-RE	227	140	342...408	---	315	53	44...110	
EVC24A-MF-RE	233	140	344...410	---	315	53	44...110	
RV24A-MF-RE	233	140	344...410	---	315	53	44...110	

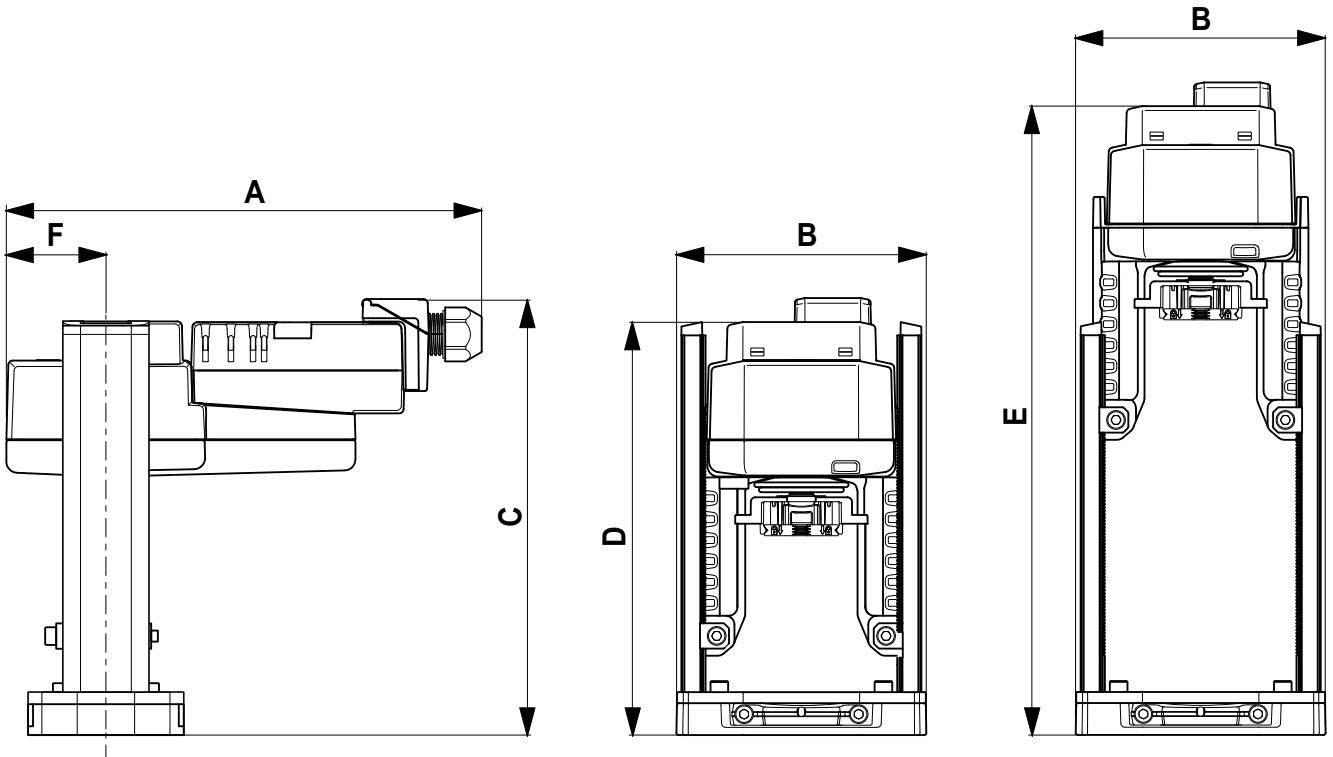

draw. 1: Actuators NV..., SV...

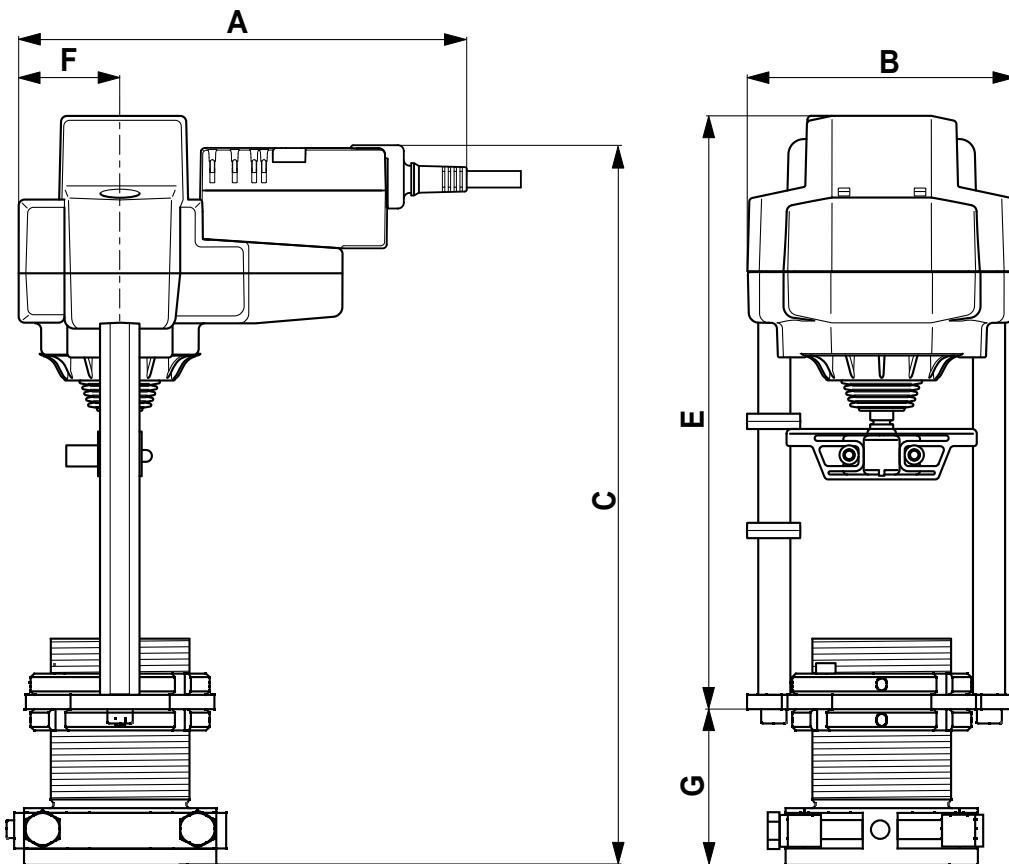

draw. 2: Actuators EV..., RV...





## Electric actuators

# Ekorex

### PTN 2

Technical data				
Type	PTN 2.20	PTN 2.25	PTN 2.32	PTN 2.40
Suitable for valves	RV 113 R, M			
Voltage	230 V + 6 %, -12 % or 24 V + 10 %, -15 % AC			
Frequency	50 Hz			
Power consumption	max. 19 VA			
Control	3 - position, (0) 4 - 20 mA, 0 - 10 V			
Nominal force	2000 N	2500 N	3200 N	4000 N
Travel	20 and 40 mm			
Enclosure	IP 65			
Process medium max. temp.	acc. to used valve			
Ambient temperature range	-20 to 60°C			
Ambient humidity range	5 to 100 % with condensation			
Weight	4 kg			

## Wiring diagram

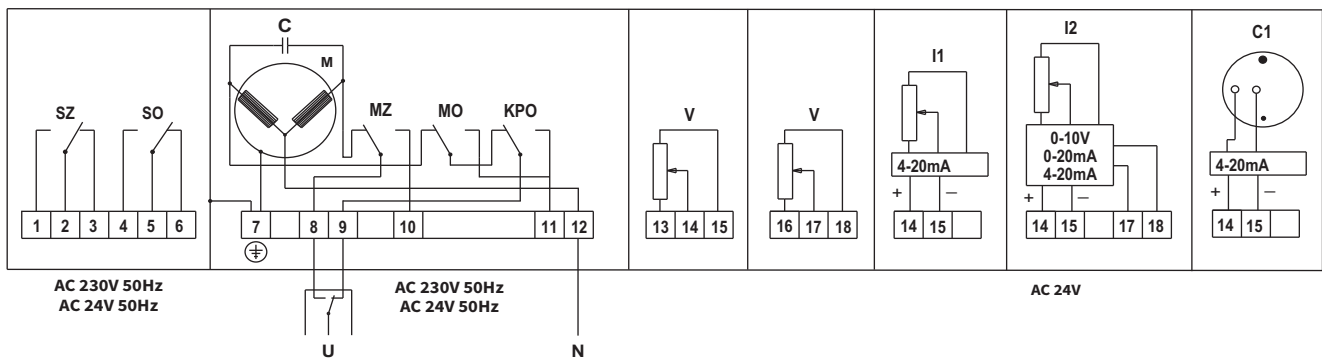

### Direct control

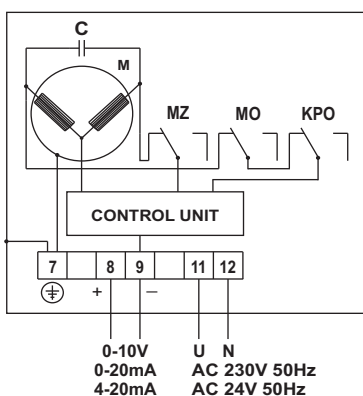

- MO** - power switch for "OPEN" position
- MZ** - power switch for "CLOSED" position
- SO** - signalisation switch for "OPEN" position
- SZ** - signalisation switch for "CLOSED" position
- KPO** - terminal position switch for "OPEN" position
- M** - motor
- C** - capacitor
- V** - resistance transmitter 100 Ω
- I1** - resistance transmitter with converter 4-20 mA - 2-wire execution
- I2** - resistance transmitter with converter - separate feeding 24V AC
- C1** - capacitive transmitter with converter 4-20 mA

## Specification of actuator PTN 2

PTN 2	X	X	X	X	X	X	X	X	Nominal force [kN]	Resetting speed [mm.min <sup>-1</sup> ]	
2	0								2	10, 16, 25, 32	
2	5								2,5	10, 16, 25, 32	
3	2								3,2	10, 16, 25, 32	
4	0								4	10, 16, 25	
	0								230 V, 50 Hz	<b>Motor supply voltage</b>	
	2								24 V, 50 Hz		
	1								10	<b>Resetting speed [mm.min<sup>-1</sup>]</b>	
	2								16		
	3								25		
	4								32		
	0								Without equipment	<b>Independent feeding 24 V</b>	
	1								Output 0 - 10 V		
	2								Output 0 - 20 mA		
	3								Output 4 - 20 mA		
	4								Output 4 - 20 mA	<b>2-wire connection</b>	
	5								Output 0 - 100 Ω 1x	<b>Resistance output signal</b>	
	6								Output 0 - 100 Ω 2x		
	7								Output - capacity transmitter 4 - 20 mA		
	8								DMS3 output		
	7								Flange D44	stem notch D7	stroke 20 mm
	8								Flange D44	stem notch D10	stroke 40 mm
	0								MO; MZ	<b>Number of microswitches</b>	
	2								MO; MZ; SO; SZ		
	8								MO; MZ; DMS3		
	9								According to agreement		
	4								20	<b>Draw bar stroke [mm]</b>	
	7								40		

### Note:

The table applies to actuator with 3-position control. It is possible to supply actuator with control signal of 0 - 10 V, 0 - 20 mA, 4 - 20 mA and with hand wheel outside

**Example of marking: PTN 2 - XX.XX.XX.XX / control 4 - 20 mA / RO)**

## Dimensions of actuator PTN 2

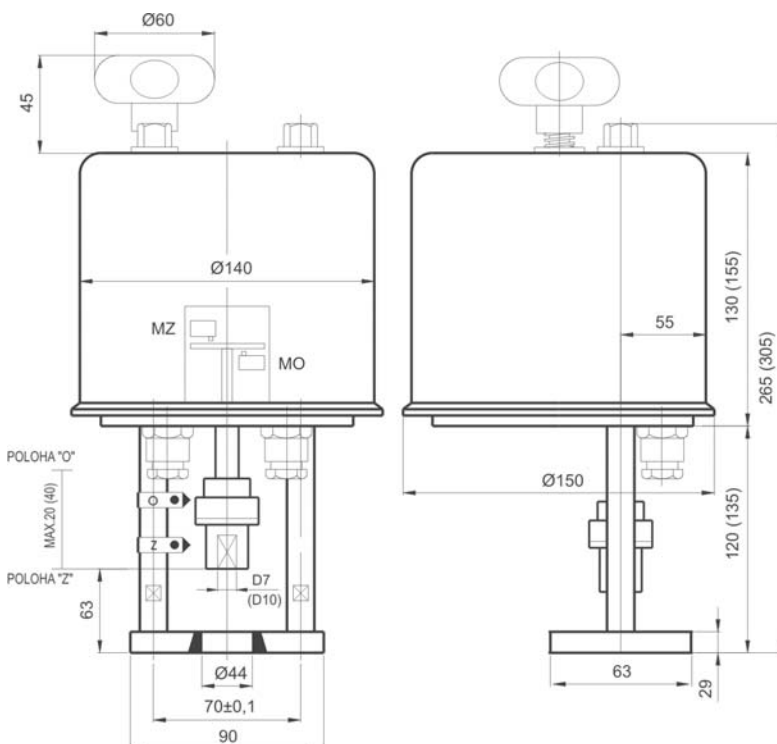



## Electric actuators

# LDM

### ANT40.11

### Description

The actuators are designed for regulators with continuous or contact output. They are suitable to actuate two-way and three-way valves series RV 113 and RV 2xx. The actuator consists of cover made of self-extinguishing plastic housing a stepping motor, control unit with SUT technology, signalisation LEDs and no-maintenance gear made of sintered steel. The connection to its valve is provided by stainless steel columns and yoke made of light metal alloy. Electric connection (max. 2,5 mm<sup>2</sup>) is provided with the aid of screw clamps. There are three self-breaking openings for cable glands M20x1,5 (2x) and M16x1,5. One cable gland M20x1,5 is a part of standard delivery.

### Application

Based on a connection variant (see wiring diagram), the actuator can be used as floating (0...10 V or 4...20 mA), or 2-position (open-closed) or 3-position (open-stop-closed). Manual operating is available with outer handle. The motor is disconnected when the hand crank is folded back. When the handle is positioned back, the actuator resumes into required position (without initialization). If the hand crank remains folded out, the actuator keeps its set position.

### Installation position

Upright, vertical, max. horizontal.

### SUT Technology

The actuator can be controlled by regulators with continuous (0...10 V and/or 4...20 mA) or contact (2-position or 3-position) output. The actuator feeding is optional. The running speed and output characteristic is also optional.

### Features

- electronic switch off based on the running force registered by stops inside appliance or valve.
- automatic adapting to the valve stroke
- code switch for characteristic and running time selection
- hand crank for manual operating with swithing the motor off as a start for new initiation
- possibility of direction change of control signal (feeding voltage at terminal 2a or 2b)

### Technical data

<b>Type</b>	<b>ANT40.11</b>
<b>Suitable for valves</b>	<b>RV 113 R, M</b>
<b>Execution</b>	Electric actuator with SUT technology
<b>Voltage</b>	24 V AC ± 20%, 50 - 60 Hz; 24 V DC ± 15%; 230 V AC ± 15%
<b>Frequency</b>	50 Hz
<b>Power consumption</b>	18 VA
<b>Control</b>	0 - 10 V, 4 - 20 mA, 3-bod., 2-bod.
<b>Open-close running time</b>	Adjustable 2, 4, 6 s.mm <sup>-1</sup>
<b>Nominal force</b>	2500 N
<b>Travel</b>	20 and 40 mm
<b>Enclosure</b>	IP 66
<b>Process medium max. temp.</b>	150°C
<b>Ambient temperature range</b>	-10 and 55°C
<b>Ambient humidity range</b>	< 95 % of relative humidity
<b>Weight</b>	4,5 kg

## Accessories

<b>0313529 001</b>	Split range unit to set sequences
<b>0372332 001</b>	Module, plug-in type, for 230 V ± 15% voltage supply and 3-point activation, additional power 2 VA
<b>0372333 001</b>	2 auxiliary changeover switches, continuously adjustable, additional load 5(2) A, 12 - 250 V, 3(1) A, 12 - 250 V AC <sup>1)</sup>
<b>0372333 002</b>	2 auxiliary changeover contacts with gold-plated contacts for low currents from 1 mA, max. 30 V, 3(1) A, 12 - 250 V AC <sup>1)</sup>
<b>0372334 001</b>	Potentiometer 2000 Ω, 1 W, 24 V <sup>1)</sup>
<b>0372334 002</b>	Potentiometer 130 Ω, 1 W, 24 V <sup>1)</sup>
<b>0372334 006</b>	Potentiometer 1000 Ω, 1 W, 24 V <sup>1)</sup>
<b>0386263 001</b>	Screwed cable gland M16 x 1,5
<b>0386263 002</b>	Screwed cable gland M20 x 1,5 (1 piece of cable gland is standard part of actuator delivery)

<sup>1)</sup> one option of accessory can be used only

## Operation

### Initialisation and feedback signal

When used as a continuous drive, the device initialises itself automatically. As soon as voltage is applied to the drive for the first time, it moves to the lower limit stop on the valve, thus enabling automatic connection with the valve spindle. Then it moves to the upper limit stop and the value is recorded and saved with the help of a path measurement system. The control signal and the feedback signal are adjusted to this effective stroke. There is no re-initialisation if the voltage is interrupted or if the voltage supply is removed. The values remain saved.

To re-initialise, the drive must be connected to the voltage. To trigger an initialisation, fold the hand crank out and back in again twice within 4 seconds. Both the LEDs will then flash red.

During initialisation, the feedback signal is inactive, or it corresponds to a value of "0". Initialisation uses the shortest run time. The reinitialisation is only valid once the entire procedure has been completed. Folding the hand crank out again will interrupt the procedure.

If the valve drive detects a blockage, it will report this by setting the feedback signal to 0 V after approx. 90 s. However, the drive will try to overcome the blockage during this time. If it is possible to overcome the blockage, the normal control function is activated again and the feedback signal is resumed.

No initialisation is performed with a 2-position or 3-position control. The feedback signal is inactive.

### Connection as a 2-point valve drive (24 V)

This activation (OPEN/CLOSED) can take place via two cables. The voltage is applied to terminals 1 and 2a. Applying the voltage (24 V) to terminal 2b opens the valve's control passage. After this voltage has been switched off, the drive moves to the opposite end position and closes the valve. The electronic motor switch-off responds in the end positions (valve limit stop, or when maximum stroke is reached) or in case of overload (no limit switches).

The coding switch can be used to set the run times. The characteristic curve cannot be selected in this case (resulting in the characteristic curve for the valve). Terminals 3i, 3u and 44 must not be connected.

### Connection as a 3-point valve drive (24 V)

Applying voltage to terminal 2a (or 2b) makes it possible to move the valve to any desired position. If voltage is applied to terminals 1 and 2b, the valve shaft moves out and opens the valve. It moves in and closes the valve when the electrical circuit is closed over terminals 1 and 2a.

In the end positions (at the valve stop, or when the maximum stroke is reached) or in case of an overload, the electronic motor switch-off responds (no limit switches). The direction of the stroke can be changed by transposing the connections.

The coding switch is used to set the run times. In this case, the characteristic curve cannot be selected (resulting in the characteristic curve for the valve). Terminals 3i, 3u and 44 must not be connected.

### Connection as a 2-point/3-point or continuous activation of valve drive with 230 V (accessory 0372332)

The accessory module is plugged on in the connection area and is then connected for 3-position mode. If this accessory is used, only control in 3-position mode is available. The coding switch on the baseboard can be used to select the run times. The characteristic curve cannot be selected; the characteristic curve for the valve is applicable.

The module has a built-in switch which is automatically moved into the correct position when the module is installed. On this drive (which has no spring return action) the switching lever is in the lower position.

The accessory module is not suitable for 2-position activation.

### Connection as continuous control (0...10 V and/or 4...20 mA) - (24V)

The built-in positioner controls the drive depending on the controller output signal.

The control signal used is a voltage signal (0...10 V-) at terminal 3u, or a current signal at terminal 3i. If a control signal is present at both terminals (3u (0...10 V) and 3i (4...20 mA)) simultaneously, the input with the higher value takes priority.

**Mode of action 1** (mains voltage to internal connection 2a):

as the output signal increases, the valve shaft moves out and opens the valve (control passage).

**Mode of action 2** (mains voltage to internal connection 2b):

as the output signal increases, the valve shaft moves in and closes the valve (control passage).

The starting point and the control span are fixed. To set partial ranges (and only for voltage input 3u), a split range unit is available as an accessory (see the split range unit function); this unit is intended for installation in the drive.

After the voltage supply is applied and after initialisation, the drive moves to each valve stroke between 0% and 100%, depending on the control signal. The electronics and the path measurement system ensure that no stroke is lost, and the drive does not require reinitialisation at intervals. When the end positions are reached, the position is checked, corrected as necessary and stored again. This ensures parallel running of several drives of the same SUT type. Feedback signal  $y_0 = 0...10V$  corresponds to the effective valve stroke of 0 to 100%.

If the 0...10 V control signal is interrupted in direction of action 1, the spindle retracts completely and the valve is closed. So that the valve can be opened (direction of action 1), a voltage of 10 V must be connected between terminals 1 and 3u, or it is necessary to switch over to direction of action 2.

The coding switch can be used to set the characteristic for the valve.

## Signal LED display

Both LEDs flashing red: initialisation procedure  
 Upper LED lit red: upper limit stop or "CLOSED" position reached  
 Lower LED lit red: lower limit stop or "OPEN" position reached  
 Upper LED flashing green: drive running, moving towards "CLOSED" position  
 Upper LED lit green: drive stationary, last direction of running "CLOSED"  
 Lower LED flashing green: drive running, moving towards "OPEN" position  
 Lower LED lit green: drive stationary, last direction of running "OPEN"  
 Both LEDs are lit green: waiting time after switching on, or after emergency function  
 No LED lit: no voltage supply (terminal 2a or 2b)  
 Both LEDs are flashing red and green: drive is in manual mode

## Accessories application

### Split range unit

This accessory can be built into the drive or can be accommodated externally in an electrical distribution box. The starting point  $U_0$  and the control span  $\Delta U$  can be set with the help of a potentiometer. This makes it possible to operate several regulating units in sequence or in a cascade with the control signal from the controller. The input signal (partial range) is converted into an output signal of 0...10V.

### Auxiliary changeover switch

Auxiliary changeover switch double 0372333001

- Switching capacity max. 250V~, min. current 250 mA at 12 V (or 20 mA at 20V)
- Switching capacity max. 12...30V=, max. current 100 mA

Auxiliary changeover switch double gold 0372333002

- Switching capacity max. 250V~, min. current 1 mA at 5V
- Switching capacity max. 0.1...30V=, current 1...100 mA

Even if used only once above 10 mA or up to 50 V, the gold coating will be destroyed. The switch can then be used only for higher switching outputs.

### Engineering and installation notes

Penetration of condensate or dripping water, etc. along the valve spindle into the drive should be avoided.

The valve is plugged directly onto the drive and is fixed with screws (no further settings are needed). The drive is automatically connected to the valve spindle. When the device is delivered, the drive spindle is in the middle position.

The housing contains three breakthrough-type cable leadthroughs which are broken open automatically when the cable leadthrough is screwed in. The stepping motor/ electronics concept guarantees parallel running of several valve drives of the same type. The cross-section of the connecting cable should be selected according to the line length and the number of drives. With five drives connected in parallel and a line length of 50 m, we recommend using a cable cross-section of 1.5 mm<sup>2</sup> (power consumption of the drive × 5). The drive can be assembled with a maximum of one 230 V module, one additional accessory component (auxiliary switch or potentiometer) and the split range unit.

### Warnings

If the temperature of the medium in the valve is high, the drive columns and the shaft may also reach high temperatures. It is necessary to ensure that the maximum ambient temperature be max. 55°C during operation. If the temperature exceeds this limit, it is recommended to insulate the valve (eg. IKA insulation, see cataloguesheet 01-09.6).

If a failure of the final control element could cause damage, additional protective precautions must be taken.

## CE - Conformity

### Directive EMC 2014/30/ES

EN 61000-6-2 \*)  
 EN 61000-6-4

### Low Voltage Directive 2014/35/ES

EN 60730 1  
 EN 60730-2-14  
 Over-voltage category III  
 Degree of pollution III

\*) HF immunity, limitation of feedback signal between 80 MHz a 1000 Mhz criterion B, otherwise criterion A

## Switch coding

### Actuator characteristic (switches 3 and 4)

- optional for actuators with floating control only

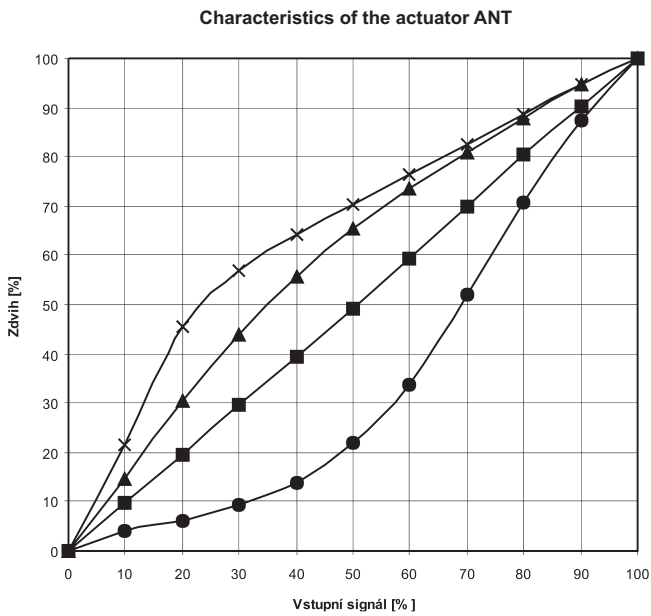

A (linear)



B (quadratic)





C (logarithmic)



D (equal-percentage)

### Run time (switches 1 and 2)

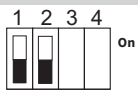
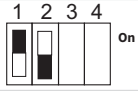
- optional for all types of control of the actuator

Run time per mm	Switch coding	Run time for stroke 20 mm	Run time for stroke 40 mm
<b>2 s / mm</b>	 On	40 s ± 1	80 s ± 2
<b>4 s / mm</b>	 On	80 s ± 2	160 s ± 4
<b>6 s / mm</b>	 On	120 s ± 4	240 s ± 8

**Note:** Data in bold mean factory settings

## Dimensions of actuator and a mid piece for higher temperatures

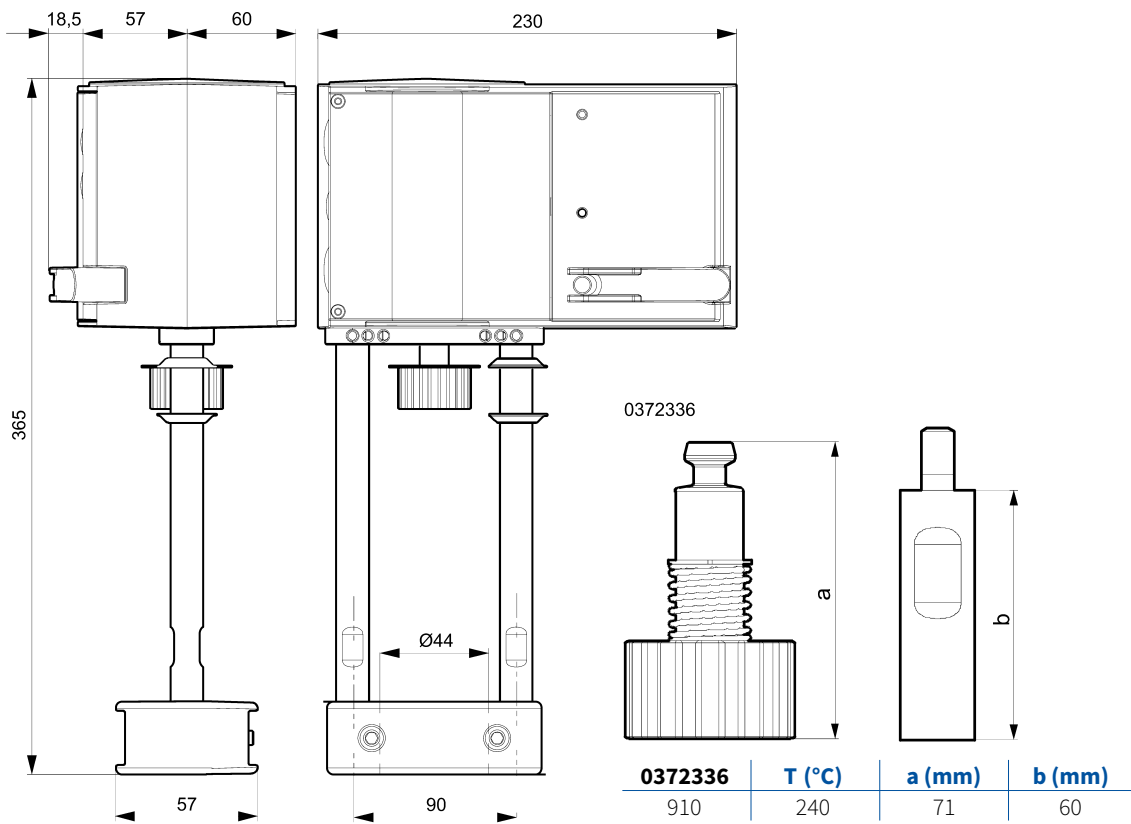

## Wiring diagram of actuators

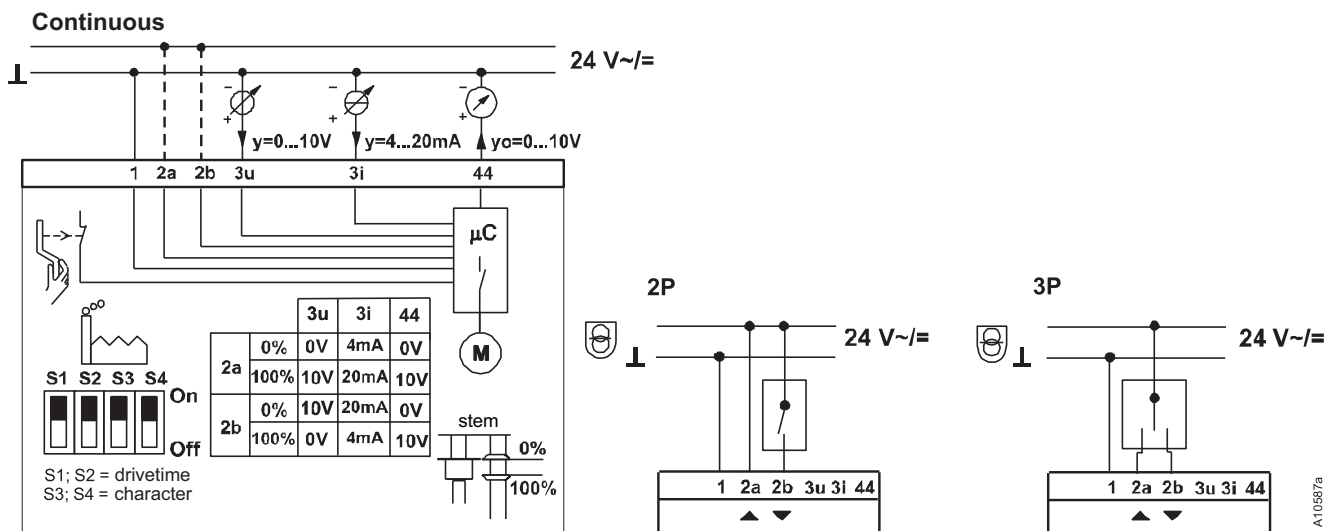

## Wiring diagram of accessories

0313529

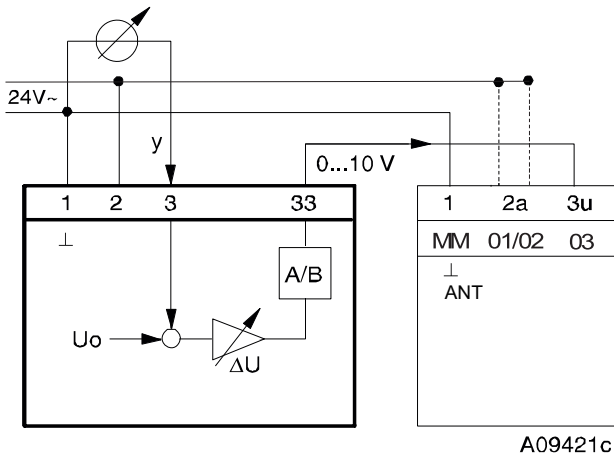

0372332001

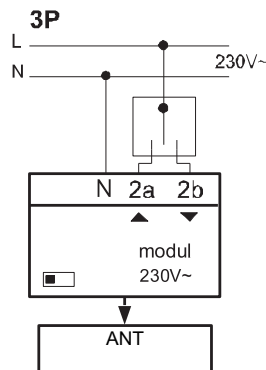
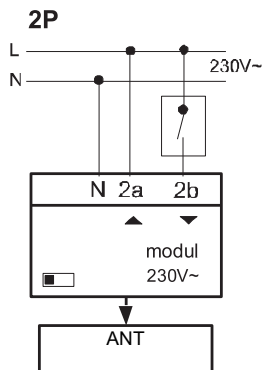
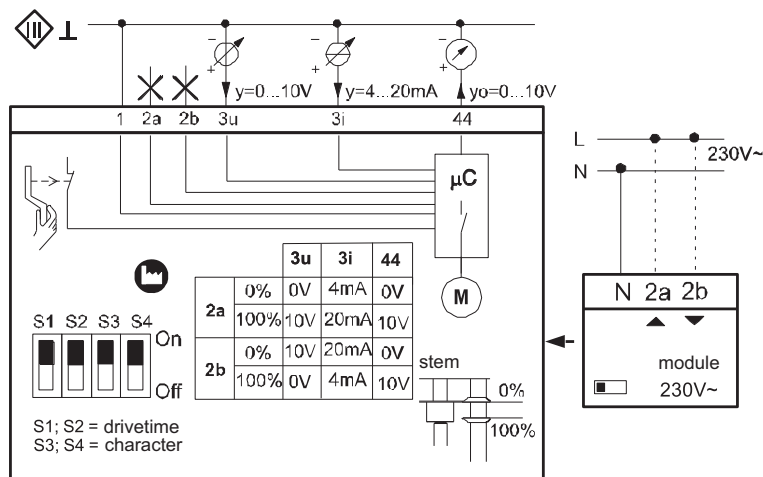

A 10564a

0372333

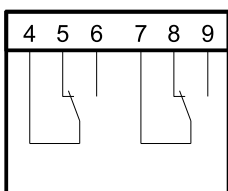

A10376

0372334

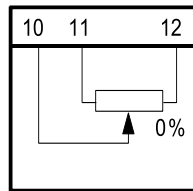

A01363





## Electric actuators

# LDM

**ANT40.11S**  
**ANT40.11R**

### Description

The actuator is designed for regulators with continuous or contact output. They are suitable for actuating two-way or three way valves series RV 113 and RV 2xx. The actuator is equipped with a spring ensuring the actuator runs into its defined end position in case of power supply failure or when the sensor of limit value is activated. The actuator consists of a cover made of self-extinguishing plastic housing stepping motor, control unit with SUT technology, signalisation LEDs and no-maintenance gear made of sintered steel and spring roll. The connection to its valve is provided by stainless steel columns and yoke made of light metal alloy. Electric connection (max. 2,5 mm<sup>2</sup>) is provided with the aid of screw clamps. There are three self-breaking openings for cable glands M20x1,5 (2x) and M16x1,5. One cable gland M20x1,5 is a part of standard delivery.

### Application

Based on a connection variant (see wiring diagram), the actuator can be used as floating (0...10 V or 4...20 mA), or 2-position (open-closed) or 3-position (open-stop-closed). Manual operating is with outer hand crank. The motor is disconnected when the hand crank is folded out. When the hand crank is folded back, the actuator resumes into required position (without initialization). If the hand crank remains folded out, the actuator keeps its set position.

### Installation position

Upright, vertical, max. horizontal.

### SUT Technology

The actuator can be controlled by regulators with continuous (0...10 V and/or 4...20 mA) or contact (2-position or 3-position) output. The actuator feeding is optional. The running speed and output characteristic is also optional.

### Features

- electronic switch off based on the running force registered by stops inside appliance or valve
- automatic adapting to the valve stroke
- code switch for characteristic and running time selection
- hand crank for manual operating with swithing the motor off as a start for new initiation
- possibility of direction change of control signal (feeding voltage at terminal 2a or 2b)

### Direct and indirect function of actuator

Direct function ensures that actuator stem extends (the valve opens) upon power supply failure.

Indirect function ensures that actuator stem retracts (the valve closes) upon power supply failure.

Technical data		
Type	ANT40.11S	ANT40.11R
Specification code	RV 113 R, M	
Execution	Electric actuator with spring return action and SUT technology	
Voltage	24 V AC $\pm$ 20%, 50 - 60 Hz; 24 V DC $\pm$ 15%; 230 V AC $\pm$ 15%	
Frequency	50 Hz	
Powe consumption	in operation mode 20 VA, in rest mode 7 VA	
Control	0-10 V, 4-20 mA, 3-position, 2-position	
Open-close running time	Adjustable 2, 4, 6 s.mm <sup>-1</sup>	
Running time for fail-safe function	Acc. to stroke 15 - 30 s	
Fail-safe function	indirect (NC)	Direct (NO)
Nominal force	2000 N	
Stroke	20 and 40 mm	
Enclosure	IP 66	
Process medium max. temperature	150 °C	
Ambient temperature range	-10 to 55 °C	
Ambient humidity range	< 95 % of relative humidity	
Weight	6,1 kg	

## Accessories

<b>0313529 001</b>	Split range unit to set sequences
<b>0372332 001</b>	Module, plug-in type, for 230 V ± 15% voltage supply and 3-point activation, additional power 2 VA
<b>0372333 001</b>	2 auxiliary changeover switches, continuously adjustable, additional load 5(2) A, 12 - 250 V, 3(1) A, 12 - 250 V AC <sup>1)</sup>
<b>0372333 002</b>	2 auxiliary changeover contacts with gold-plated contacts for low currents from 1 mA, max. 30 V, 3(1) A, 12 - 250 V AC <sup>1)</sup>
<b>0372334 001</b>	Potentiometer 2000 Ω, 1 W, 24 V <sup>1)</sup>
<b>0372334 002</b>	Potentiometer 130 Ω, 1 W, 24 V <sup>1)</sup>
<b>0372334 006</b>	Potentiometer 1000 Ω, 1 W, 24 V <sup>1)</sup>
<b>0386263 001</b>	Screwed cable gland M16 x 1,5
<b>0386263 002</b>	Screwed cable gland M20 x 1,5 (1 piece of cable gland is standard part of actuator delivery)

<sup>1)</sup>one option of accessory can be used only

## Operation

After a new start, or after a start following activation of the reset (terminal 21), up to 45 s of waiting time will pass before the drive is available again. Depending on the type of connection (see the wiring diagram), the device can be used as a continuous-action drive (0...10 V and/or 4...20 mA), a 2-point drive (open-closed) or a 3-position drive (open-stop-closed).

### Initialisation and feedback signal

The drive initialises itself automatically, whether it is used in continuous-action, 2-position or 3-position mode. As soon as voltage is applied to the drive for the first time and the waiting period has elapsed, the drive moves to the lower limit stop on the valve, thus enabling automatic connection with the valve spindle. Then it moves to the upper limit stop, and the value is recorded and saved with the help of a path measurement system. The control signal and the feedback signal are adjusted to this effective stroke. After an interruption to the voltage or a spring return action, no re-initialisation is performed and the values are saved.

To re-initialise, the drive must be connected to the voltage. To trigger an initialisation, fold the hand crank out and back in again twice within 4 seconds. Both the LEDs will then flash red.

During initialisation, the feedback signal is inactive, or it corresponds to a value of "0". Initialisation uses the shortest run time. The re-initialisation is only valid once the entire procedure has been completed. Folding the hand crank out again will interrupt the procedure.

If the valve drive detects a blockage, it will report this by setting the feedback signal to 0 V after approx. 90 s. However, the drive will try to overcome the blockage during this time. If it is possible to overcome the blockage, the normal control function is activated again and the feedback signal is resumed.

### Spring return

If the voltage supply fails or is switched off, or if a monitoring contact responds, the brushless DC motor releases the gear and the drive is moved into the respective end position (depending on the design version) by the pre-tensioned spring. As this happens, the control function of the drive is disabled for 45 s (both LEDs flash green) so that the end position can be reached in every case. The reset speed is controlled with the help of the motor so that there are no pressure surges in the line. The brushless DC motor has three functions: as a magnet to hold the position, as a brake (by acting as a generator) and as a motor for the control function. After a spring return function, the drive does not re-initialise itself.

### Connection as a 2-position valve drive (24 V)

This activation (OPEN/CLOSED) can take place via two cables. The voltage is applied to terminals 1 2a and 21. Applying the voltage (24 V) to terminal 2b causes the coupling rod to extend and opens the valve. After this voltage has been switched off, the drive moves to the opposite end position and closes the valve. The electronic motor switch-off responds in the end positions (valve limit stop, or when maximum stroke is reached) or in case of overload (no limit switches).

The coding switch can be used to set the run times. The characteristic curve cannot be selected in this case (resulting in the characteristic

curve for the valve). The feedback signal is active as long as the initialisation is performed and there is voltage present at terminal 21. Terminals 3i, 3u and 44 must not be connected.

### Connection as a 3-position valve drive (24 V)

Applying voltage to terminal 2a (or 2b) makes it possible to move the valve to any desired position. If voltage is applied to terminals 1 and 2b, the valve shaft moves out and opens the valve. It moves in and closes the valve when the electrical circuit is closed over terminals 1 and 2a.

In the end positions (at the valve stop, or when the maximum stroke is reached) or in case of an overload, the electronic motor switch-off responds (no limit switches). The direction of the stroke can be changed by transposing the connections.

The coding switch is used to set the run times. In this case, the characteristic curve cannot be selected (resulting in the characteristic curve for the valve). The feedback signal is active as long as the initialisation is performed and there is voltage present at terminal 21. Terminals 3i, 3u must not be connected.

### Connection as a 3-position valve drive with 230 V

The accessory module is plugged on in the connection area and is then connected for 3-position mode. If this accessory is used, only control in 3-position mode is available. The coding switch on the baseboard can be used to select the run times. The characteristic curve cannot be selected; the characteristic curve for the valve is applicable.

The module has a built-in switch which is automatically moved into the correct position when the module is installed. With this application, the switching lever is in the upper position.

The accessory module is not suitable for 2-position activation.

### Connection to a control voltage (0...10 V and/or 4...20 mA)

The built-in positioner controls the drive depending on the controller output signal.

The control signal used is a voltage signal (0...10 V-) at terminal 3u, or a current signal at terminal 3i.

If a control signal is present at both terminals (3u (0...10 V) and 3i (4...20 mA) simultaneously, the input with the higher value takes priority.

**Mode of action 1** (mains voltage to internal connection 2a):

as the output signal increases, the valve shaft moves out and opens the valve (control passage).

**Mode of action 2** (mains voltage to internal connection 2b):

as the output signal increases, the valve shaft moves in and closes the valve (control passage).

The starting point and the control span are fixed. To set partial ranges (and only for voltage input 3u), a split range unit is available as an accessory (see the split range unit function); this unit is intended for installation in the drive.

After the voltage supply is applied and after initialisation, the drive moves to each valve stroke between 0% and 100%, depending on the control signal.

The electronics and the path measurement system ensure that no stroke is lost, and the drive does not require re-initialisation at intervals. When the end positions are reached, the position is checked, corrected as necessary and stored again. This ensures parallel running of several drives of the same type. Feedback signal  $y_0 = 0...10$  V corresponds to the effective valve stroke of 0 to 100%.

If the control signal 0...10 V is interrupted in mode of action 1, the spindle moves in completely and the valve is closed. So that the valve can be opened (direction of action 1), a voltage of 10 V must be connected between terminals 1 and 3u, or it is necessary to switch over to direction of action 2.

The coding switch can be used to set the characteristic curve for the valve: linear, equal percentage or quadratic. This characteristic curve can only be generated if the drive is used as a continuous drive. Additional switches can be used to select the run times (applicable for 2-position, 3-position or continuous function).

## Signal LED display

Both LEDs flashing red: initialisation procedure

Upper LED lit red: upper limit stop or "CLOSED" position reached

Lower LED lit red: lower limit stop or "OPEN" position reached

Upper LED flashing green: drive running, moving towards "CLOSED" position

Upper LED lit green: drive stationary, last direction of running "CLOSED"

Lower LED flashing green: drive running, moving towards "OPEN" position

Lower LED flashing green: drive stationary, last direction of running "OPEN"

Both LEDs are lit green: waiting time after switching on, or after emergency function

No LED lit: no voltage supply (terminal 2a or 2b)

Both LEDs are flashing red and green: drive is in manual mode

## Accessories application

### Split range unit

This accessory can be built into the drive or can be accommodated externally in an electrical distribution box. The starting point  $U_0$  and the control span  $\Delta U$  can be set with the help of a potentiometer. This makes it possible to operate several regulating units in sequence or in a cascade with the control signal from the controller. The input signal (partial range) is converted into an output signal of 0...10 V.

### Auxiliary changeover switch

Auxiliary changeover switch double 0372333001

- Switching capacity max. 250 V~, min. current 250 mA at 12 V (or 20 mA at 20 V)
- Switching capacity max. 12...30 V=, max. current 100 mA

Auxiliary changeover switch double gold 0372333002

- Switching capacity max. 250 V~, min. current 1 mA at 5 V
- Switching capacity max. 0.1...30 V=, current 1...100 mA

Even if used only once above 10 mA or up to 50 V, the gold coating will be destroyed. The switch can then be used only for higher switching outputs.

### Engineering and installation notes

Penetration of condensate or dripping water, etc. along the valve spindle into the drive should be avoided.

The valve is plugged directly onto the drive and is fixed with screws (no further settings are needed). The drive is automatically connected to the valve spindle. When the device is delivered, the drive spindle is in the middle position.

The housing contains three breakthrough-type cable leadthroughs which are broken open automatically when the cable leadthrough is screwed in. The stepping motor/ electronics concept guarantees parallel running of several valve drives of the same type. The cross-section of the connecting cable should be selected according to the line length and the number of drives. With five drives connected in parallel and a line length of 50 m, we recommend using a cable cross-section of 1.5 mm<sup>2</sup> (power consumption of the drive × 5). The drive can be assembled with a maximum of one 230 V module, one additional accessory component (auxiliary switch or potentiometer) and the split range unit.

### Warnings

If the temperature of the medium in the valve is high, the drive columns and the shaft may also reach high temperatures. It is necessary to ensure that the maximum ambient temperature be max. 55°C during operation. If the temperature exceeds this limit, it is recommended to insulate the valve (e.g. IKA insulation, see catalogue sheet 01-09.6).

If a failure of the final control element could cause damage, additional protective precautions must be taken.

## CE - Conformity

### Directive EMC 2014/30/ES

EN 61000-6-2 \*)  
EN 61000-6-4

### Low Voltage Directive 2014/35/ES

EN 60730 1  
EN 60730-2-14  
Over-voltage category III  
Degree of pollution III

\*) HF immunity, limitation of feedback signal between 80 MHz a 1000 Mhz criterion B, otherwise criterion A

## Switch coding

### Actuator characteristic (switches 3 and 4)

- optional for actuators with floating control only

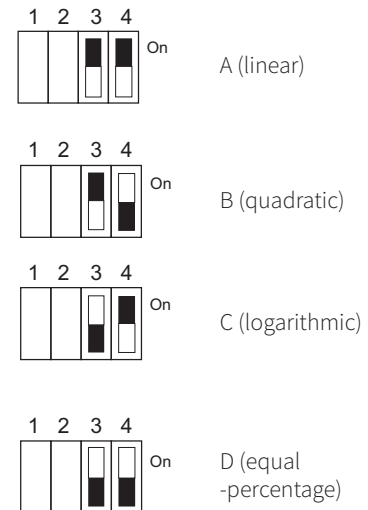
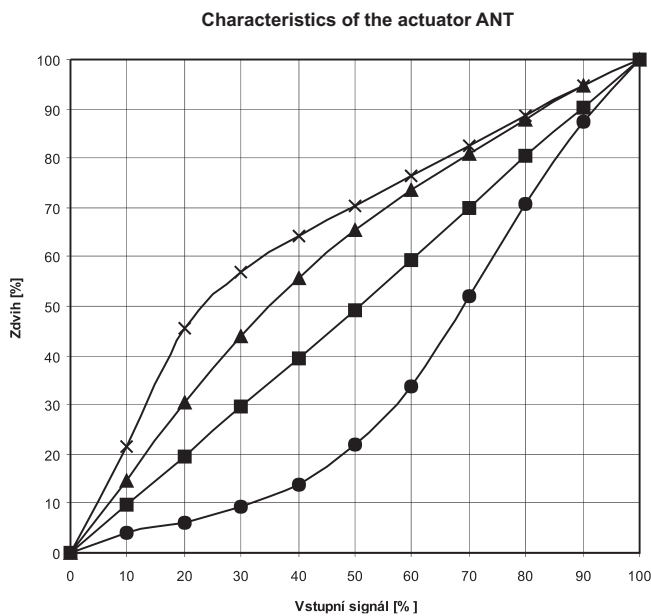

## Run time (switches 1 and 2)

- optional for all types of control of the actuator

Run time per mm	Switch coding	Run time for stroke 20 mm	Run time for stroke 40 mm
<b>2 s / mm</b>		40 s ± 1	80 s ± 2
<b>4 s / mm</b>		80 s ± 2	160 s ± 4
<b>6 s / mm</b>		120 s ± 4	240 s ± 8

**Note:** Data in bold mean factory settings

## Dimensions of actuator and a mid piece for higher temperatures

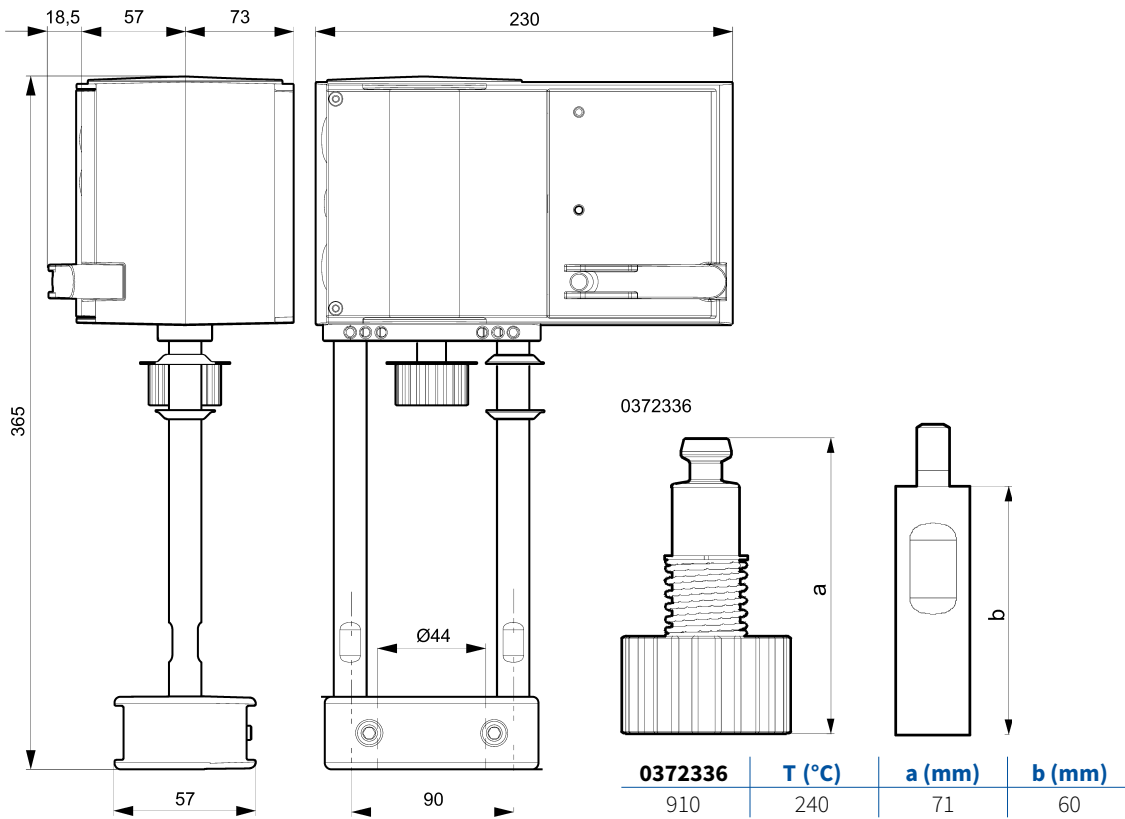

## Wiring diagram of actuators

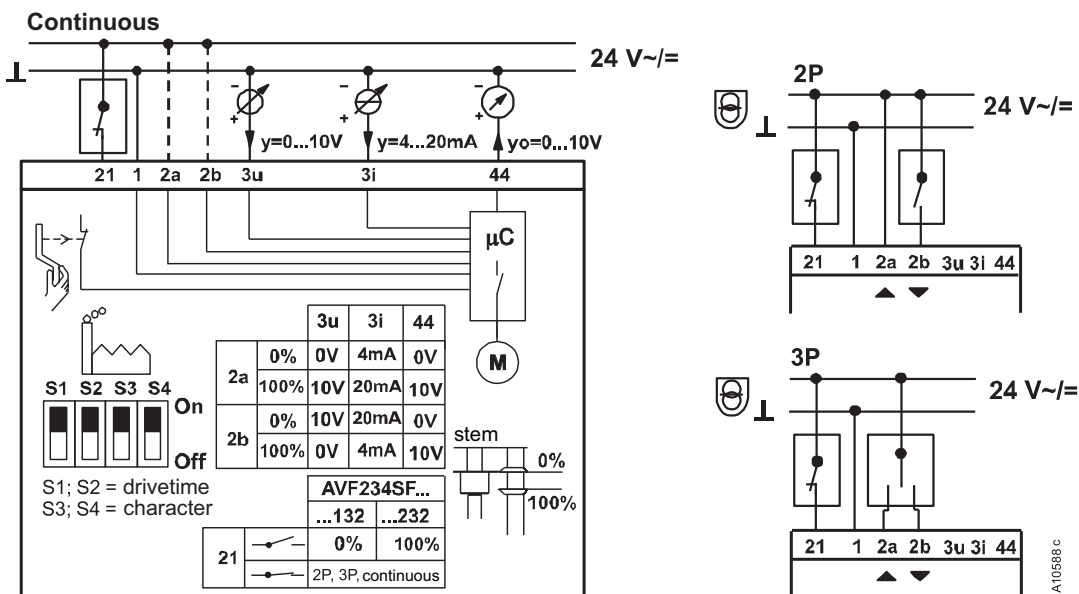

## Wiring diagram of accessories

0313529

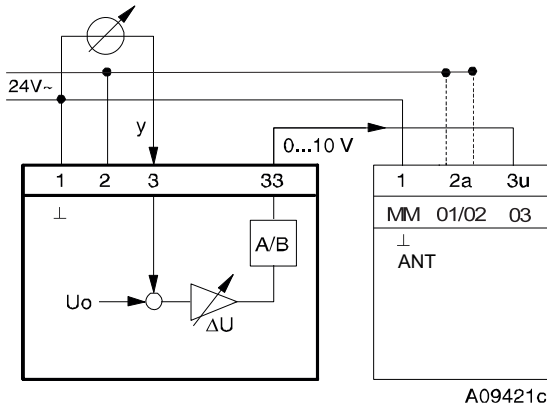

0372332001

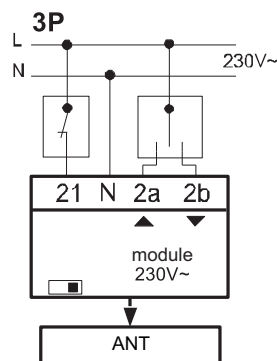
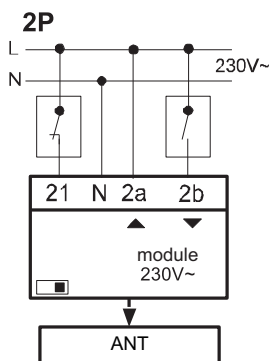
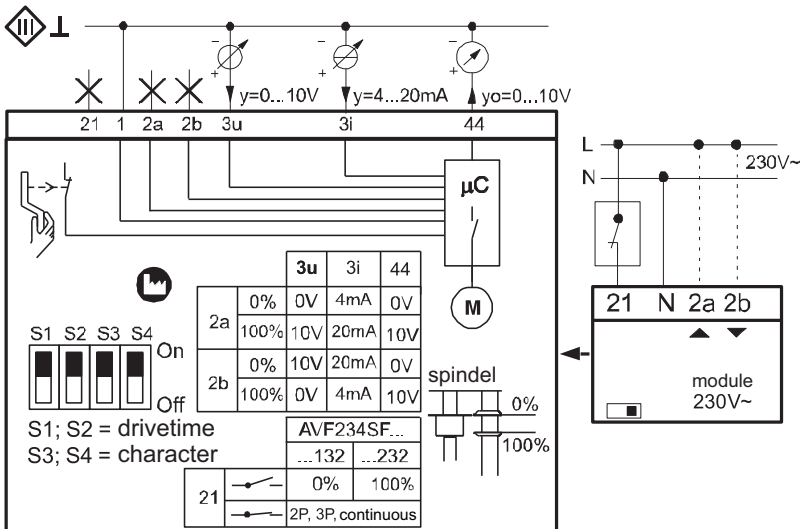

A10563c

372333

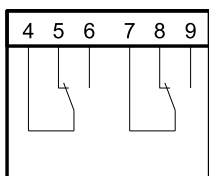

A10376

372334

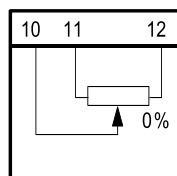

A01363



Electric actuators

## PS AUTOMATION

**PSL202 AMS11**  
**PSL204 AMS11**  
**PSL204 AMS12**

Technical data						
Type	<b>PSL202 AMS11</b>					
Suitable for valves	<b>RV 113 R, M</b>					
Voltage	AC 230 V	AC 24 V		DC 24 V		
Frequency	50 Hz					
Motor power	13 W	12 W		11 W		
Rated / Maximal current	0,07 / 0,1 A	0,7 / 0,9 A		0,4 / 0,6 A		
Control	3-position; 0(2)-10 V; 0(4)-20 mA					
Running time	adjustable value 0,45 - 0,9 mm/s					
Fail-safe action time						
Fail-safe function	electric, PSCP equipment (accessories) needed					
Nominal force	max. 2300 N					
Travel	50 mm					
Enclosure	IP 65					
Process medium max. temperature	+5 to 150 °C					
Ambient temperature range	-20 to 60 °C					
Ambient humidity range	5 ... 95 %					
Weight	8 kg without accessories / 8,4 kg with PSCP					
Type	<b>PSL204 AMS11</b>			<b>PSL204 AMS12</b>		
Suitable for valves	<b>RV 113 R, M</b>					
Voltage	AC 230 V	AC 24 V	DC 24 V	AC 230 V	AC 24 V	DC 24 V
Frequency	50 Hz					
Motor power	19 W	18 W	16 W	57 W	53 W	48 W
Rated / Maximal current	0,11 / 0,14 A	1,1 / 1,4 A	0,7 / 0,9 A	0,33 / 0,43 A	3,15 / 4,1 A	2,0 / 2,6 A
Control	3-position; 0(2)-10 V; 0(4)-20 mA					
Running time	adjustable value 0,45 - 0,9 mm/s			adjustable value 2,25 - 4,5 mm/s		
Fail-safe action time						
Fail-safe function	electric, PSCP equipment (accessories) needed					
Nominal force	max. 4500 N					
Travel	50 mm					
Enclosure	IP 65					
Process medium max. temperature	+5 to 150 °C					
Ambient temperature range	-10 to 60 °C					
Ambient humidity range	5 ... 95 %					
Weight	8 kg without accessories / 8,4 kg with PSCP					

→ The specification and technical data are informative. Detailed and latest info you can find on [www.ps-automation.com](http://www.ps-automation.com)

## Dimensions

DN	Dimensions [mm]				
	A	B	C	D	H
15 - 80	487	185	114	96	20
100 - 150	511	209	118	116	40

## Accessories (optional)

2 position signal switches, mechanical 2WE  
 2 position signal switches, gold 2WE Gold  
 Integrated PI(D) regulator PSIC  
 Electric equipment for fail-safe function PSCP  
 Profibus DP interface  
 Local control PSC.2  
 Heating resistor HR

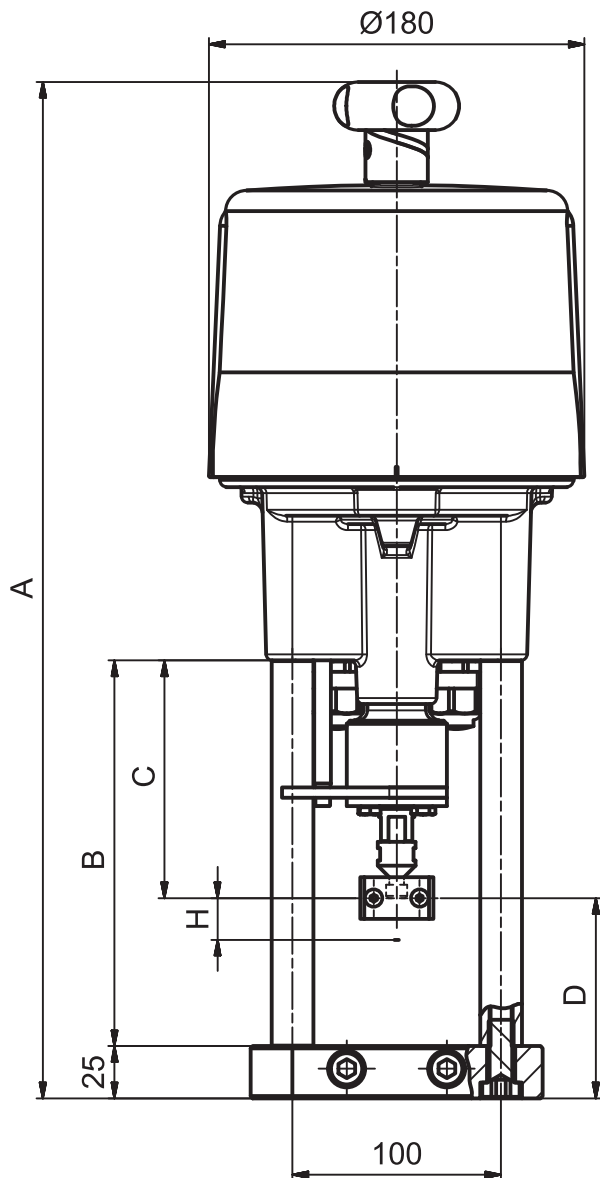





## Electric actuators

**PS AUTOMATION****PSF401, PSF402  
PSF402.1, PSF-M402**

Technical data						
Type	PSF401			PSF402		
Suitable for valves	RV 113 R, M					
Voltage	AC 230 V	AC 24 V	DC 24 V	AC 230 V	AC 24 V	DC 24 V
Frequency	50 - 60 Hz					
Motor power	6 W	6 W	5 W	9 W	9 W	8 W
Rated / Maximal current	0,08 / 0,08 A	0,4 / 0,4 A	0,2 / 0,2 A	0,14 / 0,14 A	0,7 / 0,7 A	0,35 / 0,35 A
Control	3-bodové; 0(2)-10 V; 0(4)-20 mA					
Running time	0,3 mm/s					
Fail-safe action time						
Fail-safe function	execution SE - the spring pulls the stem out of the actuator execution SR - the spring pushes the stem into the actuator					
Nominal force	1000 N			2000 N		
Travel	5 to 40 mm					
Enclosure	IP 65					
Process medium max. temperature	+5 to 150 °C					
Ambient temperature range	-10 to 60 °C					
Ambient humidity range	5 ... 95 %					
Weight	5,6 kg without accessories					
Type	PSF402.1			PSF-M402		
Suitable for valves	RV 113 R, M					
Voltage	AC 230 V	AC 24 V	DC 24 V	AC 230 V	AC 24 V	DC 24 V
Frequency	50 - 60 Hz					
Motor power	15 W	15 W	13 W	12 W	12 W	10 W
Rated / Maximal current	0,25 / 0,25 A	1,1 / 1,1 A	0,55 / 0,55 A	0,2 / 0,2 A	0,9 / 0,9 A	0,45 / 0,45 A
Control	3-position; 0(2)-10 V; 0(4)-20 mA					
Running time	0,9 mm/s +/- 10%			adjustable value		
Fail-safe action time	1,1 mm/s			0,6 / 0,9 / 1,2 mm/s		
Fail-safe function	execution SE - the spring pulls the stem out of the actuator execution SR - the spring pushes the stem into the actuator			hand wheel		
Nominal force	2 kN					
Travel	5 to 40 mm					
Enclosure	IP 65					
Process medium max. temperature	+5 to 150°C					
Ambient temperature range	-10 to 60 °C			-20 to 60 °C		
Ambient humidity range	5 ... 95 %					
Weight	5,6 kg without accessories			5,1 kg without accessories		

→ The specification and technical data are informative. Detailed and latest info you can find on [www.ps-automation.com](http://www.ps-automation.com)

## Dimensions

DN	Dimensions [mm]			
	A	B	D	H
15 - 80	319	189	76	20
100 - 150	319	189	76	40

## Accessories (optional)

2 position signal switches, mechanical 2WE  
 2 position signal switches, gold 2WE Gold  
 Integrated PI(D) regulator PSIC  
 Electric equipment for fail-safe function PSCP  
 Profibus DP interface  
 Local control PSC.2  
 Heating resistor HR

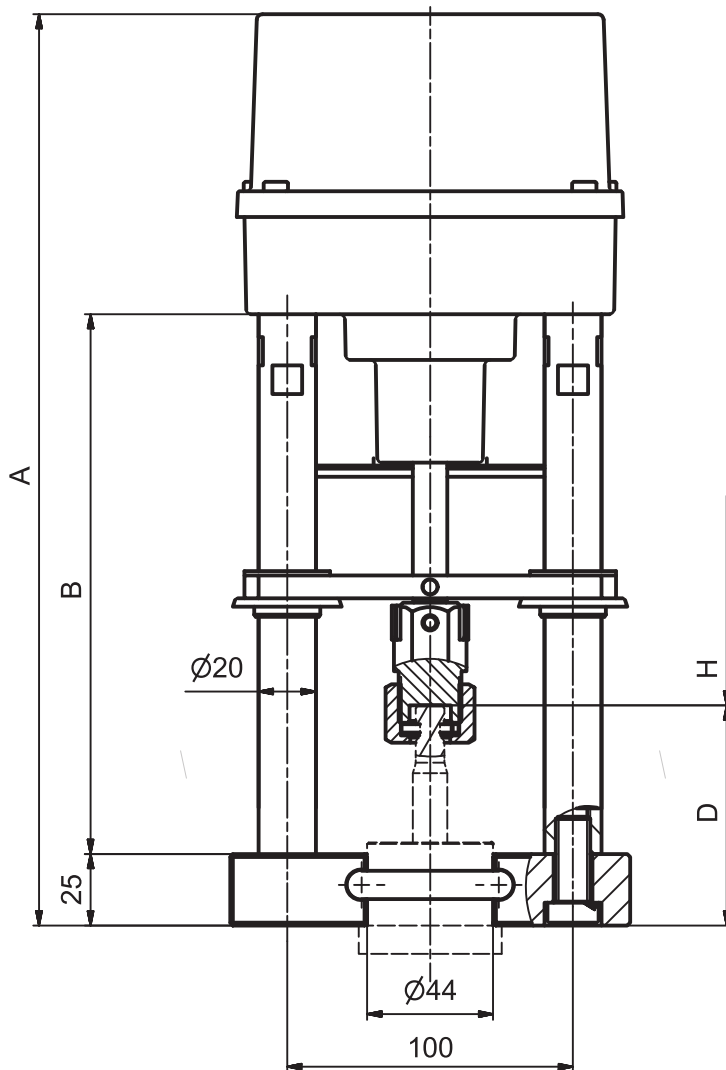



**LDM, spol. s r.o.**  
**Litomyšlská 1378**  
**560 02 Česká Třebová**  
**Czech Republic**

tel.: +420 465 502 511  
fax: +420 465 533 101  
e-mail: sale@ldm.cz

**LDM, spol. s r.o.**  
**Office Prague**  
**Podolská 50**  
**147 01 Praha 4**  
**Czech Republic**

tel.: +420 241 087 360  
fax: +420 241 087 192  
e-mail: sale@ldm.cz

**LDM, spol. s r.o.**  
**Office Ústí nad Labem**  
**Ladova 2548/38**  
**400 11 Ústí nad Labem**  
**- Severní Terasa**  
**Czech Republic**

tel.: +420 602 708 257  
e-mail: sale@ldm.cz

**LDM servis, spol. s r.o.**  
**Litomyšlská 1378**  
**560 02 Česká Třebová**  
**Czech Republic**

tel.: +420 465 502 411-3  
fax: +420 465 531 010  
e-mail: servis@ldm.cz

**LDM Bratislava s.r.o.**  
**Mierová 151**  
**821 05 Bratislava**  
**Slovakia**

tel.: +421 2 43415027-8  
fax: +421 2 43415029  
e-mail: ldm@ldm.sk

**LDM, Polska Sp. z o.o.**  
**ul. Bednorza 1**  
**40 384 Katowice**  
**Poland**

tel.: +48 32 730 56 33  
fax: +48 32 730 52 33  
mobile: +48 601 354 999  
e-mail: ldmpolska@ldm.cz

**LDM Armaturen GmbH**  
**Wupperweg 21**  
**D-51789 Lindlar**  
**Germany**

tel.: +49 2266 440333  
fax: +49 2266 440372  
mobile: +49 177 2960469  
e-mail: ldmmaturen@ldmvalves.com

**OOO "LDM Promarmatura"**  
**Jubilejnyj prospekt,**  
**dom.6a, of. 601**  
**141400 Khimki Moscow Region**  
**Russia**

tel.: +7 4957772238  
fax: +7 4956662212  
mobile: +7 9032254333  
e-mail: inforus@ldmvalves.com

**TOO "LDM"**  
**Shakirova 33/1**  
**kab. 103**  
**100012 Karaganda**  
**Kazakhstan**

tel.: +7 7212 566 936  
fax: +7 7212 566 936  
mobile: +7 701 738 36 79  
e-mail: sale@ldm.kz

**LDM - Bulgaria - OOD**  
**z. k. Mladost 1**  
**bl. 42, floor 12, app. 57**  
**1784 Sofia**  
**Bulgaria**

tel.: +359 2 9746311  
fax: +359 2 9746311  
mobile: +359 888 925 766  
e-mail: ldm.bg@ldmvalves.com

# www.ldmvalves.com

LDM reserves the right to modify or improve the designs or specifications of such products at any time without notice.

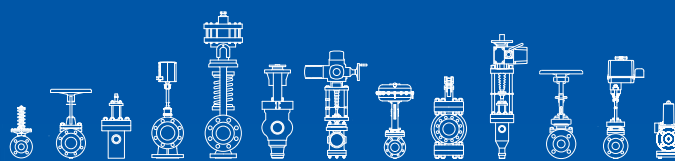
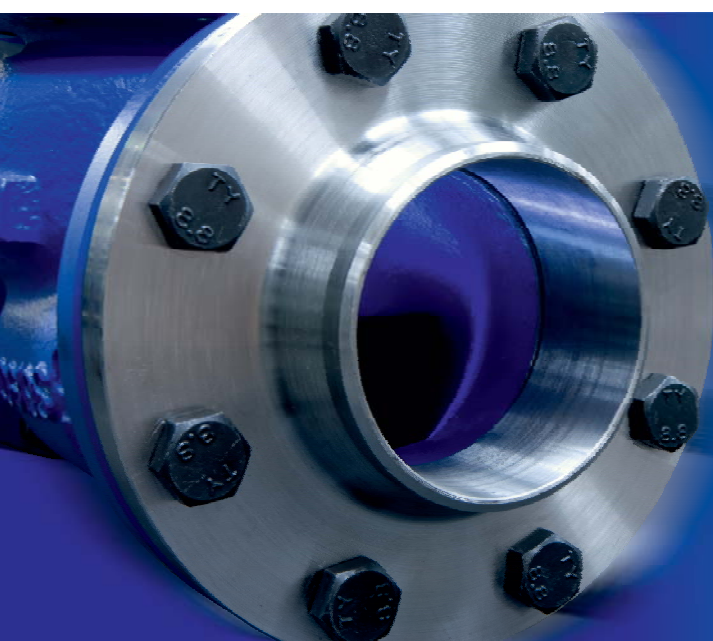

# POWER THROUGH IDEAS